



**Super Systems Inc.**

7205 Edington Drive  
Cincinnati, OH 45249  
513-772-0060  
Fax: 513-772-9466  
[www.supersystems.com](http://www.supersystems.com)



Cut-out Size: 7.40" W X 5.56" H

# Model 9200 Controller

USER'S MANUAL

*Super Systems Inc. help desk:  
1-513-772-0060*

**Super Systems Inc.**

USA Office

*Corporate Headquarters:*

7205 Edington Drive

*Shipping Address:*

7245 Edington Drive

Cincinnati, OH 45249

Phone: (513) 772-0060

<http://www.supersystems.com>

**Super Systems Europe**

Unit E, Tyburn Trading Estate,

Ashold Farm Road, Birmingham

B24 9QG

UNITED KINGDOM

Phone: +44 (0) 121 306 5180

<http://www.supersystemseurope.com>

**Super Systems México**

Sistemas Superiores Integrales S de RL de CV

Acceso IV No. 31 Int. H Parque Industrial

Benito Juarez

C.P. 76120 Queretaro, Qro.

Phone: +52 442 210 2459

<http://www.supersystems.com.mx>

**Super Systems China**

No. 369 XianXia Road

Room 703

Shanghai, CHINA

200336

Phone: +86 21 5206 5701/2

<http://www.supersystems.cn>

**Super Systems India Pvt. Ltd.**

A-26 Mezzanine Floor, FIEE Complex,

Okhla Indl. Area, Phase - 2

New Delhi, India 110 020

Phone: +91 11 41050097

<http://www.supersystemsindia.com>

Table of Contents

Safety .....	5
About This Manual.....	7
Controller Description .....	7
Model 9200 Terminals Connections .....	8
Additional Features .....	8
Ethernet Connections .....	8
Mechanical Installation and Mounting.....	9
Electrical Installation .....	10
Instrument Start-up .....	10
Flash Card & Flash Card Reader .....	10
Operator Interface Screen Saver .....	10
<b>Chapter 1 - INSTALLATION</b> .....	<b>11</b>
Mounting .....	11
Default Status Screen.....	11
Display .....	11
Loops Display .....	12
Menu Display .....	12
Menus .....	13
Program Display .....	14
Quench / Zone Instrument Assignments (Read-only).....	15
Chart.....	15
Alarm Ack.....	16
Data Logging using Flash Card.....	16
<b>Chapter 2 - CONFIGURATION</b> .....	<b>17</b>
Configuration Menu .....	17
Program Edit .....	17
Factor Entry.....	18
Burnoff.....	18
Auxiliary Instruments (Read-only) .....	18
Auxiliary Analog Input (Read-only).....	19
Shutdown (Display).....	19
Adjust Date and Time .....	19
Slave Communications Status .....	20
Backup Compressed Data.....	20
Manual Event Control .....	20
Probe Burn off Setup .....	20
PID Loop Setup (Includes cycle time and more....).....	21
Event Run Program Setup.....	22
Zone / Load TC Setup.....	22
Port Setup .....	23
Instrument Setup .....	23
Zone Assignments.....	25
Furnace Setup .....	26
Default Wait Limits.....	26
Furnace Name .....	26
Alarm Setup.....	27
Relay Assignments.....	27
Relay Set Points .....	28
Analog Input Setup .....	29
Analog Output Setup.....	29

## **Model 9200 Programmable Dual-loop Controller**

---

Passcode and Alarm.....	30
IP Address .....	30
Event Control .....	31
Valve Setup – USED ONLY IN THE NITRIDING VERSION .....	31
Valve Inputs –USED ONLY IN THE NITRIDING VERSION .....	32
Programmer Setup .....	32
Recipe Transfer .....	32
User Calibration .....	32
Full Calibration .....	35
Set Menu Security .....	35
Read/Write Raw Data .....	36
Tuning Assistant .....	36
Curve Entry.....	37
Alternate PID Setup.....	38
Analog Input Board Setup .....	38
AI Board Calibration .....	38
ADAM Correction .....	38
Aux SP Configuration.....	39
<b>Chapter 3 - PROGRAMS</b> .....	<b>40</b>
Overview.....	40
Program Editing.....	40
<b>Chapter 4 - SERIES 9200 Opcodes</b> .....	<b>41</b>
Programmer Description .....	41
Opcodes .....	41
<b>Chapter 5 - APPLICATIONS INFORMATION</b> .....	<b>46</b>
9200 MMI Protocol Register Mapping.....	46
Default Values.....	46
Sample Recipe - % Carbon and Temperature (Batch Furnace) .....	49
Standard Event Assignments .....	49
Flash Card Management.....	49
SDRecorder Installation.....	51
Slave Instrument Mapping .....	53
<b>Revision History</b> .....	<b>64</b>

Safety

- *Safety Symbols* - Various symbols are used on the instrument, they have the following meaning:



Caution (refer to the accompanying documents)



Functional earth (ground) terminal

The functional earth connection is required for safety purposes and to ground RFI filters.

- *Personnel* - Installation must only be carried out by technically qualified personnel.
- *Enclosure of live parts* - To prevent hands or metal tools from touching parts that may be electrically live (powered), the controller must be installed in an enclosure.



- *Caution: Live sensors* - Do not connect live (powered) sensors to any signal input on the controller. Live sensors are sensors that must be connected to the main's supply. The controller has transient protection circuits connected between the inputs and the earth connection, which might be damaged by live (powered) sensors.
- *Wiring* - It is important to connect the controller in accordance with the wiring data given in this handbook. Take particular care not to connect AC supplies to the low voltage sensor input or other low-level inputs and outputs. Only use copper conductors for connections (except thermocouple inputs) and ensure that the wiring of installations comply with all local wiring regulations. For example, in the United Kingdom use the latest version of the IEE wiring regulations, (BS7671). In the USA use NEC Class 1 wiring methods.
- *Power Isolation* - The installation must include a power isolating switch or circuit breaker. This device should be in close proximity to the controller, within easy reach of the operator and marked as the disconnecting device for the instrument.
- *Earth leakage current* - Due to RFI Filtering there is an earth leakage current of less than 0.5mA. This may affect the design of an installation of multiple controllers protected by Residual Current Device, (RCD) or Ground Fault Detector, (GFD) type circuit breakers.
- *Over current protection* - To protect the internal PCB tracking within the controller against excess currents, the AC power supply to the controller and power outputs must be wired through a fuse or circuit breaker specified in the technical specification.
- *Voltage rating* - The maximum continuous voltage applied between any of the following terminals must not exceed 264VAC:
  - line or neutral to any other connection
  - relay or triac output to logic, DC or sensor connections
  - any connection to ground.

The power supply/controller should not be wired to a three-phase supply with an unearthed star connection. Under fault conditions such a supply could rise above 264Vac with respect to ground and the product would not be safe.

Voltage transients across the power supply connections, and between the power supply and ground, must not exceed 2.5kV. Where occasional voltage transients over 2.5kV are expected or measured, the power installation to both the instrument supply and load circuits should include a transient limiting device. These units will typically include gas discharge tubes and metal oxide varistors that limit and control voltage transients on the supply line due to lightning strikes or inductive load switching. Devices are available in a range of energy ratings and should be selected to suit conditions at the installation.

- *Conductive pollution* - Electrically conductive pollution must be excluded from the cabinet in which the controller is mounted. For example, carbon dust is a form of electrically conductive pollution. To secure a suitable atmosphere in conditions of conductive pollution, fit an air filter to the air intake of the cabinet. Where condensation is likely, for example at low temperatures, include a thermostatically controlled heater in the cabinet.
- *Over-temperature protection* - When designing any control system it is essential to consider what will happen if any part of the system should fail. In temperature control applications the primary danger is that the heating will remain constantly on. Apart from spoiling the product, this could damage any process machinery being controlled or even cause a fire. Reasons why the heating might remain constantly on include:
  - the temperature sensor becoming detached from the process
  - thermocouple wiring becoming a short circuit
  - the controller failing with its heating output constantly on
  - an external valve or contactor sticking in the heating condition
  - the controller set point set too high

Where damage or injury is possible, we recommend fitting a separate over-temperature protection unit, with an independent temperature sensor, which will isolate the heating circuit. Please note that the alarm relays within the controller will not give protection under all failure conditions.

- *Grounding of the temperature sensor shield* - In some installations it is common practice to replace the temperature sensor while the controller is still powered up. Under these conditions, as additional protection against electric shock, we recommend that the shield of the temperature sensor be grounded. Do not rely on grounding through the framework of the machine.
- *Installation requirements for EMC* - To ensure compliance with the European EMC directive certain installation precautions are necessary. When using relay or triac outputs it may be necessary to fit a filter suitable for suppressing the emissions. The filter requirements will depend on the type of load. For typical applications we recommend Schaffner FN321 or FN612.
- *Routing of wires* - To minimize the pick-up of electrical noise, the wiring for low voltage DC and particularly the sensor input should be routed away from high-current power cables. Where it is impractical to do this, use shielded cables with the shield grounded at one end.

## Model 9200 Programmable Dual-loop Controller

### About This Manual

This instrument is designed to be custom-configured for each specific application and customer need. The applications (addendum's to the general manual) include atmosphere control, vacuum furnace control and nitriding control (% dissociation). Each addendum is application specific showing the specific screens and terminal connections.

### Controller Description

The Model 9200 is a multi-loop Proportional Integral Derivative (PID) controller that can be custom configured to control a variety of different applications. General features of this product include:

The Model 9200 is powered by 24 VDC, not LINE Voltage. Please be careful when connecting power to this controller. Connecting anything other than 24 VDC will cause serious damage.



Approximate Box Dimensions	2.75" x 4" x 4.5"
Operating Range	32° F - 132° F
Power Requirements	24VDC, 4 Watts
Digital Output Rating	300VAC / 1 AMP
Analog Output Load Rating	1000 Ohms (Total)
Controller Enclosure Rating	IP10 – hand protected
Number of RS232 Ports	One (1)
Number of Ethernet Ports	One (1)
Number of RS485 Host Ports	One (1)
Number of RS485 Slave Ports	Two (2)
Number of Internal Relays	Eight (8)
Number of Analog Inputs	Three (3)
Number of Analog Outputs	Two (2)
Number of Digital Inputs	Four (4)
Number of Control Loops	Three (3)

The variety of input and output combinations allows SSi to configure the Model 9200 to control furnace **atmosphere** (temperature and % carbon), to control **vacuum** furnaces (temperature and vacuum gauges), and to control **nitriding** (temperature, % dissociation, and back-pressure). There are special occasions where the three analog inputs have been used to control 3-zones of temperature.

Model 9200 Terminals Connections

<b>SUPER SYSTEMS INC.</b> (800) 666-4330 www.supersystems.com		
1 - 24VDC (COM)	12 - RELAY OUT 5	22 - SLAVE 2 RS485 (+)
2 - 24VDC (+)	13 - RELAY OUT 6	23 - SLAVE 2 RS485 (-)
3 - RS485 RT (-)	14 - RELAY OUT 7	24 - 4-20mA OUT 1 (-)
4 - RS485 RT (+)	15 - RELAY OUT 8 NC	25 - 4-20mA OUT COM (+)
5 - SLAVE 1 RS485 (-)	16 - RELAY OUT 8 NO	26 - 4-20mA OUT 2 (-)
6 - SLAVE 1 RS485 (+)	17 - DIGITAL IN 1	27 - ANALOG IN 3 (-)
7 - RELAY COMMON	18 - DIGITAL IN 2	28 - ANALOG IN 3 (+)
8 - RELAY OUT 1	19 - DIGITAL IN 3	29 - ANALOG IN 2 (-)
9 - RELAY OUT 2	20 - DIGITAL IN 4	30 - ANALOG IN 2 (+)
10 - RELAY OUT 3	21 - DIGITAL IN COM	31 - ANALOG IN 1 (-)
11 - RELAY OUT 4		32 - ANALOG IN 1 (+)

Additional Features

The Operator Interface (touch screen) contains a removable compact Flash Card that can be used to transfer data from the Model 9200 to a computer. This flash card acts like a removable hard drive, however it is very small and contains no moving parts to make it very portable. It is located on the back of the touch screen (see *Flash Card & Flash Card Reader*).

Also included is a Utility Software CD that includes SSi's Super Data (SD) Charting. SD Charting is a utility program that can be loaded onto any Windows® based computer (operating Windows 98® or higher). This software will allow the computer to read the data from the Model 9200, and allow it to be charted in a manner that is similar to a strip chart recorder.

The Operator Interface is normally accessed via the touch-screen, however connections also exist that will allow the operator to use a traditional mouse and keyboard to enter information.

Ethernet Connections

The Ethernet connection has three distinct uses. The first is should the Operator Interface fail, the Ethernet connection allows a laptop to be connected to the Series 9200 DIN rail mounted unit. This connection can act as a LIMITED FUNCTION "operator interface" until the Operator Interface can be repaired or replaced. The laptop needs to be operating a WINDOWS 98® or higher with Internet Explorer. The default IP address is **192.168.0.200**. If you are experiencing problems please call 513-772-0060 and talk with our computer communications personnel. The second use for the Ethernet port would be for communications to a SCADA



---

## Model 9200 Programmable Dual-loop Controller

---

software package. Call us at **513-772-0060** if you are interested in this option. The third use for the Ethernet Port is the primary communications connection for the Configurator Software.

### Mechanical Installation and Mounting

The Model 9200 Operator Interface is generally flush-mounted, either in an existing enclosure, on a “plate” that will be retrofitted to an existing enclosure, or on a new enclosure specifically designed for its particular application. Installation begins by securing the new enclosure to the floor or wall, securing the retrofit plate to the door of the existing enclosure, or flush-mounting the Operator Interface in a cut-out of the existing enclosure. When tightening the retaining clips on the Operator Interface, it is important to make them snug but not to over-tighten them. Over-tightening can warp the bezel and cause irreparable damage to the Operator Interface.

1. There is an adhesive waterproof gasket on the front bezel. Ensure that the waterproof gasket is in place before installing the TPC system in the panel opening.
2. Install the TPC in the panel opening.
3. Retrieve the clamps and long screws from the accessory pack. Hook the clamps the holes located on the four sides of the bezel. Insert screws into every clamp and tighten them to fasten the clamp in place. These screws will push against the mounting panel and secure the unit.
4. The suggested mounting panel thickness is less than 6 mm (0.236 in).
5. The suggested mounting screw torque is 2 KGF-cm (kilogram-force centimeter) or 0.14 ft\*lb (foot pound) (*Finger tight + ¼ turn + removable Loctite*)

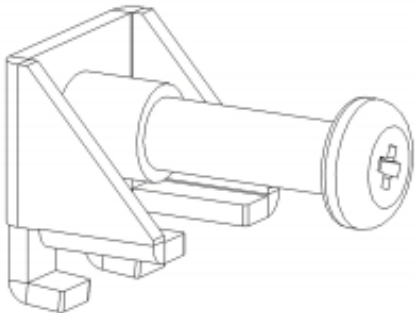

Insert the screws into each clamp and tighten them to fasten the clamp in place.

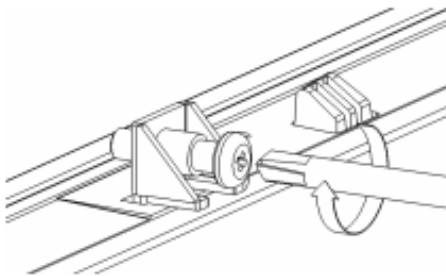

Hook the clamps into the holes and fasten the screws  
Torque: 2 kgf-cm  
These screws will push the mounting panel and secure the unit.

The DIN rail mount portion of the controller (the Model 9200 and the 24 VDC power supply) needs to be located in close proximity to the existing wires that were connected to the older control unit being replaced. These units should be secured prior to making any electrical connections.

### Electrical Installation

The Model 9200 requires 24VDC, 4 Watt, 60 Hz, single-phase power. A 24 VDC power supply is required and is generally included as part of the Model 9200 system. This power supply has a universal input that can accept between 60 and 265VAC. Power should be applied in accordance with the electrical drawings that have been supplied. Since each installation is unique for each site, the customer is responsible for providing adequate power and making it available to the Model 9200 power supply.

### **SSi requirement:**

MOV's must be wired across the isolation relay coil terminals on all isolation relays that are connected to solenoids. **Further...** MOV's must be connected across the HOT and NEUTRAL wires when the solenoid is wired to them. **IT IS AN ABSOLUTE MUST to have the MOV's at BOTH LOCATIONS.**

### Instrument Start-up

On power-up, the Operator Interface will display a logo screen for thirty seconds and then switch to the default Status screen. The logo display can be terminated early by touching the screen.

### Flash Card & Flash Card Reader



***Never remove the flash card when the Operator Interface is "ON".***

To properly shut down the Operator Interface, press the **Menu** button, and select *Shutdown*. At the prompt, press *Yes* to shut down the Operator Interface. This will bring you to a conventional Microsoft Windows screen. Sliding the black switch to the OFF position (located directly over the green power connector, on the back of the Operator Interface) will turn off the power to the Operator Interface.

Once the Operator Interface is turned off, remove the compact flash card cover at the top of the display unit, exposing the card. Press the black release button and the card will pop out of the slot. To replace the flash card, simply return the card to the slot making sure that the release button is in it's UP position, and replace the flash card cover to its proper position. To restore power to the unit, move the black switch to the right or ON position.

### Operator Interface Screen Saver

The Operator Interface has a default screen saver. It automatically "blanks" the screen after ten (10) minutes of non-activity. To disengage the screen saver, simply touch the screen and it will re-appear.

## Chapter 1 - INSTALLATION

### Mounting

The Series 9200 Operator Interface mounts into a panel or on a plate by using the enclosed 8 mounting brackets. With the exception of the Operator Interface, these items can be mounted on a standard DIN rail for mounting inside an electrical enclosure. SSi supplies a 10-foot communications cord with the two connectors and the piece of DIN rail required for the components that have been ordered.

Operator Interface Cutout: 7.40"W X 5.56"H



### Default Status Screen

#### Display

The Status Display shows the atmosphere and temperature controller information as well as an overview of the programmer. There are six active buttons on the Status Display: **Loops**, **Menu**, **Program**, **Quench Zone**, **Chart** and **Alarm Ack**. One hidden button is located behind the SSi Logo. By activating this button selected Software and Firmware information will be displayed.

- The **Loops** button will switch the display to the two control loops, % Carbon on the left and Temperature on the right.
- The **Menu** button will switch to the menu. The blue UP and DOWN arrow keys move you from one selection to another. The **Enter** button will enter the selected Menu Screen, if access is authorized.
- The **Program** button will switch to the Program Display. This is a companion display to the status screen and is described below.
- The **Quench Zone** button will switch to the Quench and Zone Display. This is a companion display to the Status Screen and is described below.
- The **Chart** button will switch the display to the video recorder display. Use of the Chart Display is explained below.
- The **Alarm Ack** button is used to acknowledge an alarm. The alarm is displayed in the lower left-hand corner of the Status Screen. A red **ALM** block in the top right corner of the screen

displays an alarm condition. The alarm will either be a flashing number, which indicates a program operator alarm, or a flashing message, which indicates a program system alarm.

Loops Display

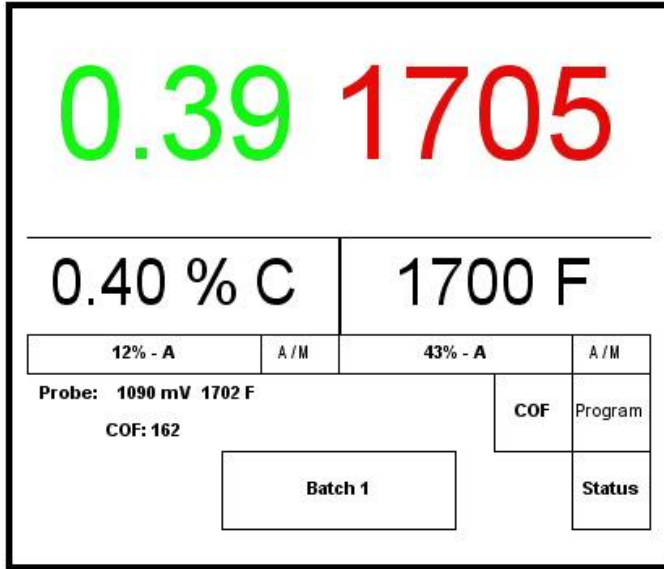

The current process variable is displayed at the top, with each loop set point displayed beneath the process variable. The operator can change the process set point by touching the screen area below the large process variable numbers. When pressing the Temperature or % Carbon set point a numeric keypad is displayed, showing the current value and allowing you to enter a new set point by simply pressing on the appropriate numeric keys. Once the correct set point has been entered, press the **Enter** key to make the change. When the **Enter** key is pressed the display returns to the Loops Screen. The other active keys within the Loop Screen are the two **A/M** (Auto/Manual) buttons. Pressing either of those buttons moves you to a display page asking for a supervisor or administrative pass code. Pressing the proper numeric keys and pressing the **Enter** button changes the

controllers mode from Auto to Manual, or from Manual to Auto depending on which mode it was in when the **A/M** key was pressed. If you are in the manual mode, you may press that button on the Loops Screen and a numeric keypad appears, allowing you to enter a % output to control the "loop" in a manual mode.

Also displayed are the probe millivolts, the probe temperature, and the COF Factor. The COF factor can also be adjusted from this screen. After pushing the **COF** button a numeric screen pad pops up and allows the authorized personnel to make the appropriate change.

The Loops Screen also allows you to move back to the default Status Screen or to the Program Screen to view the program currently running on the Series 9200 Dual Loop controller.

Menu Display

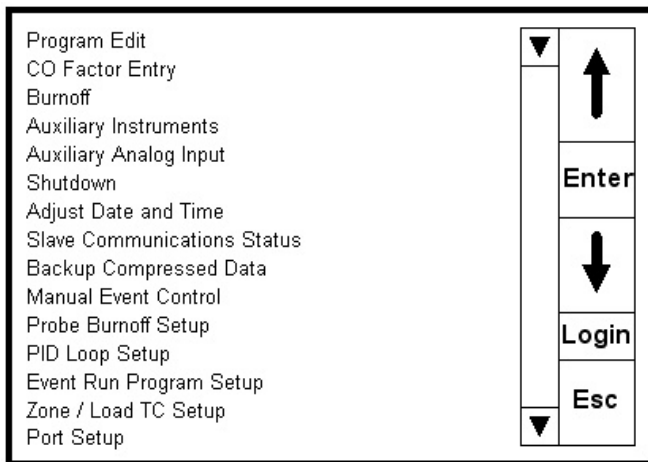

The remaining items on the Menu Display are:

- Instrument Setup
- Zone Assignments
- Furnace Setup
- Default Wait Limits
- Furnace Name
- Alarm Setup
- Relay Assignments
- Relay Setpoints
- Input Setup
- Output Setup
- Passcode and Alarm
- IP Address
- Event Control
- Valve Setup
- Valve Inputs
- Programmer Setup
- Recipe Transfer
- User Calibration
- Full Calibration
- Set Menu Security
- Read/Write Raw Data
- Tuning Assistant
- Curve Entry
- Alternate PID Setup
- Analog Input Board Setup
- AI Board Calibration
- ADAM Correction
- Aux SP Configuration

### Menus

There are three levels of menus in the Series 9200.

- The first level is the *operator level*. These are functions or operations that are typically handled by the furnace operator. This menu is accessed without the need for a pass code.
- The second level is to be used by a *supervisor*. This level requires the entry of a level 1 or level 2-pass code.
- The third level is the *configuration level*. This requires the level 2-pass code ONLY.

As shipped, the level 1 and level 2 codes are set as **1** and **2** respectively. The pass codes can be changed at the Passcode and Alarm Screen.

The menu has five operating buttons located on the right side of the screen. The UP arrow moves the cursor from bottom to top. The **Enter** button activates the selection that the operator has chosen, the DOWN arrow key moves the cursor from top to bottom, the **Login** key activates another screen that allows access to the Supervisor Menu and the Configuration Menu, and the **Esc** key takes you back to the previous screen without any action being taken.

Pressing the **Login** key takes you to the numeric keypad Enter Password Screen. Entering the correct password (the default password is "2") displays the Supervisor Menu, which includes the entire list of menus necessary to configure the Series 9200. These are explained in detail in *Chapter 2 – Configuration*.

Program Display

Pressing the **Program** key displays the default Program Status page.

The Program Status Display shows the last program loaded into the program run buffer and its status. If the program is running, the active step number is highlighted, and the status is running. A red **ALM** block in the top right corner of the screen displays an alarm condition.

The Program Display has seven active buttons located on the right side of the display. Touching the inside of the blocks activates these. The active buttons are **Soak Adjust, Load, Stop, Hold, Cont, Alm Ack (Alarm Acknowledge)** and **Esc**.

<b>OK</b>	<b>Batch 1</b>				<b>Soak Adjust</b>
Program 1	Status: Stopped			0:00	<b>Load</b>
Remaining Time	Step: 0:00			Total: 0:00	
1	SETPT	1750		wait	<b>Stop</b>
2	SETPT	1700	1.00	wait	
3	SOAK			1:00	
4	EVT-OUT			3-ON	<b>Hold</b>
5	SETPT	1600		wait	
6	DELAY			10	<b>Cont</b>
7	EVT-OUT			3-OFF	
8	SETPT	1600	0.80	wait	<b>Alm Ack</b>
9	SOAK			0:30	
10	EVT-OUT			1-ON	<b>Esc</b>
11	ALARM			1	
12	EVT-OUT			1-OFF	

- The **Soak Adjust** button allows you to enter a new value for the time remaining in the current soak or ramp cycle. A soak or ramp cycle must be running for a change in soak/ramp time to be adjusted.
- The **Load** button allows the operator to enter the recipe number to be run and to view the recipe before pushing the **Run** button. Pushing the **Run** button starts the recipe. If a recipe program is running and the operator enters a new recipe program it can be viewed and modified. The recipe does not become active until the **Run** button is pushed. Pressing **Run** places the program currently being viewed in the active memory and will begin to run the new recipe. You can start the program in any step, simply by moving the highlight down to the step that that the program needs to be started in, and then pressing the **Run** key.

While reviewing the program that is about to be run, certain parameters within those steps can be modified. You can change the set points, the time and the options. You CAN NOT delete a step, or modify it's OPT CODE.

- The **Stop** button stops the recipe program that is currently displayed. Stop means exactly that! It stops the program. It is NOT a hold button. See hold below. To re-start the program if it has been stopped you must use the **Load** button, enter the recipe number, and then highlight the segment number of the recipe that you want to start with and initiate *Run*.
- The **Hold** button places the displayed recipe program in hold. Once a decision is made that affects the recipe, it may be continued by pressing the **Cont** button.
- The **Cont** button re-starts the displayed (active) recipe, where it was placed in hold at.
- The **Alm Ack** displays the Alarm Screen. From here you can acknowledge the alarm, in most cases it will be acknowledging *end of soak*. The alarm must be acknowledged to allow the program to go to the next step.
- The **Esc** button returns you to the default Display Screen.

Quench / Zone Instrument Assignments (Read-only)

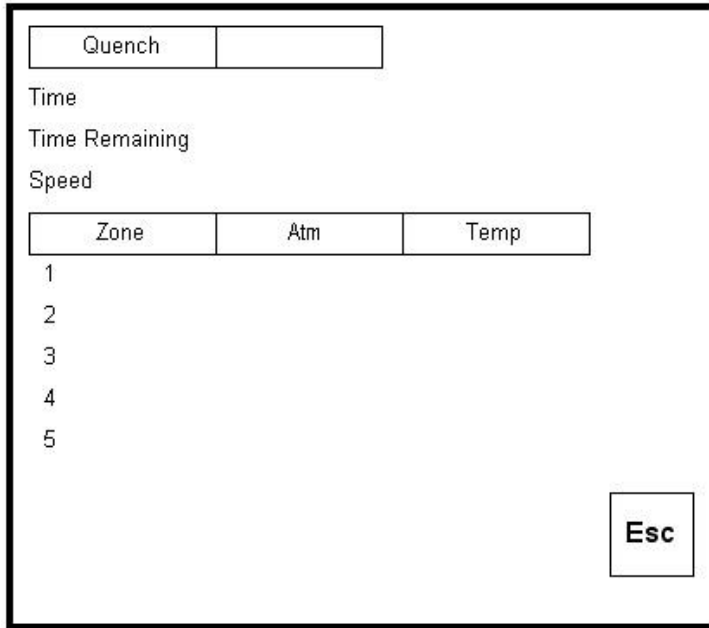

The Quench / Zone Instrument Assignments Display shows two groups of information, both of which are dependent on CONFIGURATION or OPT CODE use. The quench portion will only display if the quench opcode was executed in a program. This will then show the total quench time, the time remaining, and the quench speed. The zone group will display the process variables that have been assigned in the zone assignment configuration.

Chart

The Chart Display shows between 15 minutes and 7 days of process variable data on the screen, and can be scrolled back to view all of the data stored on the hard drive (72 hours at a time). The vertical timelines change as the time changes on the screen. A chart is available for the LP1 and LP2 only and a chart is available for the LP1 and LP2 plus their set points. You can toggle between the two charts by pressing the **PREV** and the **NEXT** keys.

The **Prev** and **Next** arrows change the display from one chart to another (i.e. from just process variables to process variables and set points.)

The blue **RIGHT** and **LEFT** arrows move the displayed chart along the horizontal axis, going back and forward in time and then returning to real time.

The **+** and **-** keys change the time window displayed on the screen.

The **Note** key allows the operator to enter a note on the chart, similar to writing on a paper chart. The note shows up when the chart is printed out using the utility software included with the Series 9200 instrumentation. The interface must be the ADVANTECH 5.7-inch with the Flash Card.

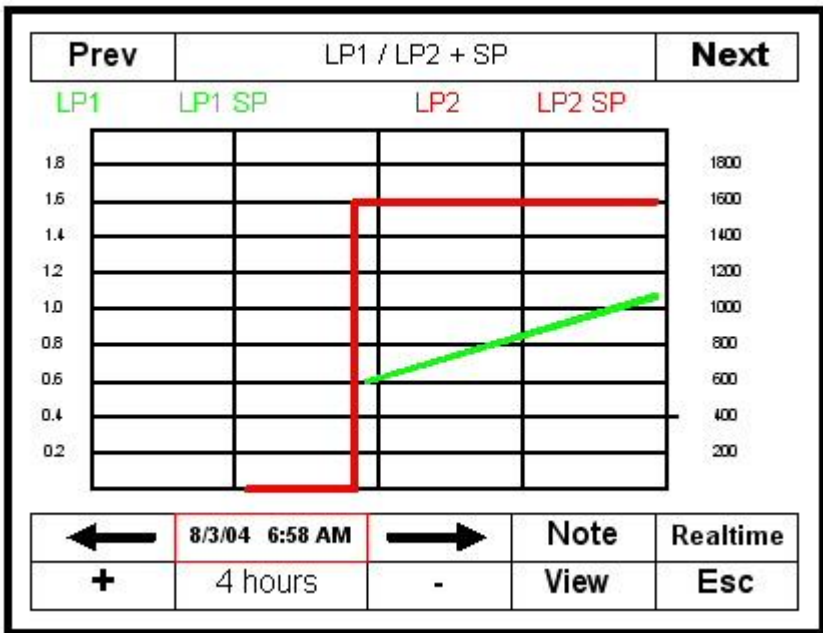

Pressing the **Note** key displays an alphanumeric keypad asking for operator ID or initials. Pressing the appropriate keys and then pressing the **<- Enter** key displays another alphanumeric keypad and prompts the operator to enter a note. After pressing the keys on this keypad and then **<- Enter** key, the next screen displayed asks you where you want the note written. The default choice is the current time and date. You can change the parameters and place the note at whatever time and date is required. Pressing the **OK** key takes you back to the real time chart page.

Pressing the **Realtime** key brings the chart display back to the current time.

The **View** key allows you to look at the NOTES that have been stored with the chart.

### Alarm Ack

The **Alarm Ack** button displays the Active Alarm Screen. From which you can acknowledge any alarms that have been configured, or that have been made part of the recipes that run on the Series 9200. If a recipe has an alarm as a step, the alarm must be acknowledged before the recipe will continue to the next step.

### Data Logging using Flash Card



**NOTE: See Warnings with respect to removing the Flash Card.**

The Advantech TPC-642S/642-SE touch screen Operator Interface utilizing a Compact Flash Card allows the unit to data log the parameters setup by a qualified SSi technician. Should a customer not take his data offline in a timely manner, the data will be over-written, the oldest data being that which is over-written first. Here is how it works:

1. When the ADVANTECH Operator Interface detects that there is less than 5% disk space left on the compact flash card, an alarm will be displayed on the main interface screen stating "x% disk space remaining (overwrite at 3%)". In the upper right corner, an ALM is indicated, but because it is not a communications alarm or a 9200 device alarm, the background remains green. This alarm will remain active until more than 5% of disk space is available for writing data log files.
2. If the user does not copy the log data from the disk, it will eventually fall to 2% disk space. At this point, the touch screen will select the oldest compressed file and delete it. It then checks to see if 3% remains. It repeats this procedure until 3% disk space remains. At this point the alarm message changes to "Overwriting data log data!" Because this allows the system to seesaw between 2% and 3%, it will continue to display "Overwriting data log data!" until somebody offloads the files.

Technical concerns and details:

1. If there are not enough compressed files to bring the free space up to 3%, the system will hunt down and kill hourly files. This should only happen if compression would not be running for some reason.
2. If all compressed files and hourly files have been removed and there is still not enough disk space (perhaps a problem with the compact flash card), the data logger will not write to the disk until the condition is remedied. (Alarms continue to display).
3. The data log data alarm is the lowest priority. The alarm priorities are touch screen communications, then 9200 controller/programmer, then disk space.



Configuration Menu

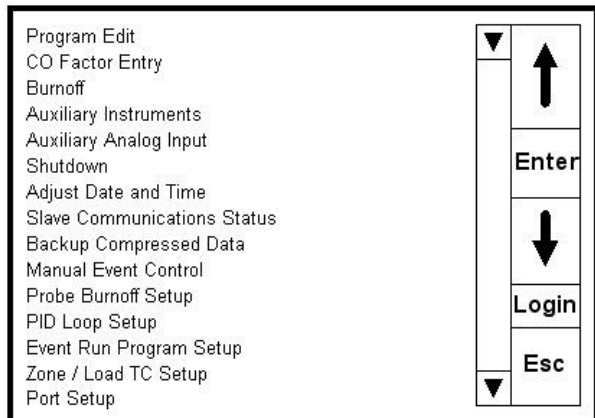

The Configuration Menu is entered through the **Menu** key that is part of the 7 buttons running down the right side of the Default Display Screen. Pressing the **Login** key that is below the blue up and down arrow keys displays a numeric keypad. Enter the correct passcode for the configuration level and press the **Enter** key. This displays the following configuration options:

Program Edit

Selecting this **Program Edit** button pops up another screen which asks the operator to enter a program number to be edited. Enter **0** to edit a blank program. To ERASE/DELETE an existing recipe/program you need to SAVE it as program Zero (0). Program 0 is a NO-OPT program.

When you enter a number for a stored program and push the **Enter** key the program steps are displayed. Using the up and down arrow keys you select the step in the existing program that you wish to edit. Move the cursor to that step and press the **Enter** key. The next screen to pop up will show the step's parameter and it's value.

**NOTE: A list of OPCODES appears in the Appendix of this manual.**

Example:

Parameter equals OPCODE, Value equals SOAK.

Parameter equals TIME, Value equals 3:45.

Highlighting the opcode and soak and pressing the **Enter** key brings up a screen that shows all of the possible opcodes. Selecting the opcode that you want to use for the program step that you are editing and pressing the **Enter** key.

If you desire to change the time highlight the time and press the **Enter** key. The next screen is the Time Edit Screen. To change the hour, press the **Hour** key in the upper right-hand corner. If you want to change the minutes press the **Min** key. The next screen that pops up in both cases is a numeric keypad. Enter the time that you wish to permanently change the recipe to and press the **Enter** key. If you DO NOT wish to make any changes press the **Esc** key. Note, if you wish to only change the minutes, you must enter the desired hour(s), if other than 0.

If you have made a change, pressing the **Enter** key takes you back to the Time Edit Screen. If you wish to make the change, press the **Set** key on the right-hand side of the screen. The next screen to pop up verifies the time has been changed to the number of minutes that you have selected. Pressing the **Cancel** key takes you back to the full Program Screen. If you are sure that you want the change to be permanent press the **Set** key. This takes you back to the screen that shows you the entire program. Notice that the time has been changed on the program segment that you were editing. If you wish to save this change press the **Save** key. You will notice that a numeric keypad pops up and asks you to enter the number of the program that you wish to save. You must enter the desired program number you wish to save these changes to.

*NOTE: See the APPENDIX section of this manual for a sample program.*

The **Insert** button will insert a step into the recipe.

The **Delete** button will delete a step from the recipe.

The **Esc** button takes you back to the Default Menu.

Factor Entry

Highlighting the **Factor Entry** and pressing **Enter** pops up the Factor Entry Screen, showing the parameter as CO Factor or H Factor and Value as is currently in the Series 9200. To make an adjustment, press the **Enter** key. A numeric keypad will be displayed. Using the keypad, enter the number that you wish the CO Factor to be and press the **Enter** key. This returns you to the original Factor Entry Screen, which now shows the new CO Factor that you have entered. If you do not wish to make the change simply press the **Esc** key which takes you back to the Factor Entry Screen with NO change being made to the CO Factor.

The COF factor allows you to make adjustments that will allow the controller to match the results obtained when measuring shim stock. If the controller set point and the process variable are the same, but you are not attaining the desired surface Carbon, you can make the adjustment with the COF Factor to increase the amount of surface Carbon available to the parts. If you lower the COF factor, it immediately lowers the % Carbon process variable. This will cause the controller to add more enriching gas--- raising the process variable until once again the process variable and the set point match. Conversely, raising the COF Factor will cause the process variable to read higher, shutting down the enriching gas solenoid (possibly turning on the air dilution solenoid) causing the % Carbon process variable to begin to lower (NOT ADDING ENRICHING GAS) until the set point and process variable match.

Pressing the **Esc** button takes you back to the Menu Screen.

Burnoff

*NOTE: All timer functions are in SECONDS*

The Burnout Display shows the following information:

Burnout, impedance test, when the next automated burnout is scheduled, the test status, the countdown timer, the probe mV's, the probe T/C, the last burnout date, the last impedance test date, and the time that it took for the probe to recover.

This screen will allow personnel to start a probe burn off or impedance test, by highlighting the desired test and pressing the **Enter** button.

Parameter	Value	
Burnoff	0	↑
Impedance Test	0	
Next burnoff in	868 min	Enter
Test status	idle	
Timer (sec)	0	↓
mV	0	
TC	0	Esc
Start mV	0	
Start TC	n	↓
Last Burnoff	3/9/05 5:52:03 PM	
Last Imp. Test	Invalid Date Time	
Last Recovery	0 Sec	↓

Auxiliary Instruments (Read-only)

Instrument	PV
1	0
2	0
3	0
4	0
5	0
6	0
7	0
8	0
9	0
10	0
11	0
12	0

The Auxiliary Instruments Display shows the following information:  
The instruments slaved to the Series 9200 and their process variables.

Auxiliary Analog Input (Read-only)

The Auxiliary Analog Input Display shows the information from any attached analog input modules such as: load T/C's, flows from Waukeetric flow meters, etc.

Mdl	Value
Input 1	1140
Input 2	1654
Input 3	985
1	
2	
3	
4	
5	
6	
7	
8	
CJ	

Shutdown (Display)

The Shutdown selection pops up another screen asking whether or not you wish to shutdown the interface with the Series 9200. Two responses are possible Yes or No.

When you shutdown the ADVANTECH interface, the SERIES 9200 controller is still functioning. You can monitor it by connecting the ETHERNET connection to a laptop computer, using Internet Explorer, and assigning a legitimate IP address.

“Yes” shows you a typical computer screen with the **Start** button in the bottom left-hand corner. You can now turn the power off to the operator interface without upsetting any of the settings. The “No” response returns you to the initial Status Screen. *Shutting down the Operator Interface does not shutdown the Series 9200 Controller.*

Adjust Date and Time

Pressing **Enter** moves you to screen Clock setup.

Highlighting the date and pressing **Enter** moves you to a screen Date Edit.

The current date in the Series 9200 is displayed as well as the date on a scroll type display. Touching the individual parts of the date [day (Monday, Tuesday, etc.), month, and year] will highlight that portion of the date, and using the little up and down arrow keys will allow you to adjust the highlighted value.

Pressing the **Set** button makes the change permanent.

If you desire to change the time highlight the time and press the **Enter** key. The next screen is the Time Edit Screen. To enter the hour, press the **Hour** key in the upper right-hand corner. If you want to change the minutes press the **Min** key. The next screen that pops up in both cases is a numeric keypad. Enter the time that you wish to change the time to and press the **Set** key. If you DO NOT wish to make any changes press the **Cancel** key. Note, if you wish to only change the minutes, you must also enter the hour in 24-hour (Military) format.

Pressing the **Cancel** key takes you back to the Clock Setup Screen.

Slave Communications Status

Pressing the **Enter** key displays the auxiliary instruments and their status, if any. There are five possible messages that can occur to describe the instrument communications status.

- N/A – No instrument is connected
- Bad – No communications exist
- ??? – Communications exist, but there are frequent errors
- ?OK – Communications exist, but there are occasional errors
- OK – Communication is established and working properly

This is a display only screen.

Backup Compressed Data

Pressing **Enter** displays the Backup Datalog Data.

This screen is NOT functional at this time.

Manual Event Control

Pressing **Enter** displays the Manual Event Control Screen.

Highlighting a specific event and pressing the **Enter** key changes the displayed status of the highlighted event. This will activate or deactivate whatever digital contact is connected to that particular event.

Pressing the **Esc** key returns you to the original Menu Screen.

Event	Status
0	off
1	off
2	off
3	off
4	off
5	off
6	off
7	off
8	off
9	off

Probe Burn off Setup

Pressing the **Enter** key moves you to the Burn off Setup Screen. This screen shows the parameters and values associated with a probe burn off.

*NOTE: All timer functions are in SECONDS*

Burn off Time (sec), Burn off Recovery Wait Time (sec), Burn off Interval (min), Minimum Burn off Millivolts, and Maximum Burn off Temperature, Digital IN 3 starts burn off. If the burn off does not force the oxygen probe to read below 800 mV's then it does not record the burn off, and if the maximum temperature reaches a value greater than the value indicated it will shutdown the burn off procedure to prevent damage to the probe. Signal input at Digital Input 3 could be used to initiate probe burn off.

Highlighting any of the parameters and pressing the **Enter** key displays a numeric keypad that allows the operator/supervisor to change the current value. Pressing the **Enter** button after pressing the keypad to change the value moves you back to the Burn off Setup Screen.

Pressing the **Enter** button or the **Esc** button at this point takes you back to the Menu Screen.

### PID Loop Setup (Includes cycle time and more....)

Pressing the **Enter** key moves you to the PID Screen, showing you **Loop 1** and its control parameter (i.e. % Carbon, etc.) and **Loop 2** and its parameter (i.e. temperature)

The TOP two blue arrows move you from one loop to the other. Pressing the down top arrow moves you from Loop 1 to Loop 2. Below each of the loops are shown the PID parameters as they exist in the Series 9200 at that particular moment.

Highlighting the loop and pressing the **Enter** key activates the lower two up and down blue arrow keys, separated by the **Enter** key. Using the lower up and down arrow keys allows the operator/supervisor to highlight the parameters shown in the lower portion of the screen. These editable parameters include Proportional Band, Reset and Rate, Set point, Pct Out (when in Manual Mode), Mode, Integral Preset, Cycle Time, SP Change Limit, Control Mode, Low Limit, High Limit, 0 SP stops ctrl. Some of the parameters are view only, such as Probe Millivolts, Process Variable, Pct Out (while in Auto Mode), SP Lower Limit, and SP Upper Limit. Pressing the **Enter** key when the parameter is highlighted can change all of the other parameters. This will move you to a numeric keypad that will allow you to change the specific parameter. In some cases the keypad is non-active. You are given a menu of choices. Highlight your choice and press the **Enter** key to make the appropriate selection.

Change set point overshoot protection:

When the Change Set point is set to any value other than OFF, the PID control operates normally until there is a set point change. When a set point change occurs, the PID algorithm uses PB only (i.e. it ignores the (I) Reset and (D) Rate) until the % output from the specified loop falls below the value specified. At this time it begins calculating Reset and Rate and returns to normal operation.

Example: Change set point is set at 80%.

Current set point is 1500.

New set point is 1700 - % output rapidly goes to 100%, PID ignores Reset and Rate.

Temperature gets within PB, % output starts to drop.

When % output drops below 80%, PID operation returns to normal with Reset and Rate applied.

Normally overshoot is caused by a buildup of the Reset error term, by ignoring this term until the temperature is with PB; the Reset term is minimized thus reducing the overshoot error. You should be cautious not to set the change set point value too low. (E.g. if the furnace controls 1700 in a steady state at

## Model 9200 Programmable Dual-loop Controller

50% output and you set the change set point value to 40% and the PB value is low, you could find yourself in a situation where you never see 40% output and remain in a **PB only** control mode.)

Default PID Parameters for Loop 1(% Carbon) and Loop 2 (Temperature)

Loop 1 Default PID Parameters	Loop 2 Default PID Parameters
Proportional Band: 20	Proportional Band: 4.0
Reset: .10	Reset: 0.10
Rate: 0	Rate: 0
Cycle time: 16	Cycle time: 60

The **Cancel** key on some of the screens returns you to the previous screen without any changes being effected. The **Esc** key takes you back to the Menu Screen.

### Event Run Program Setup

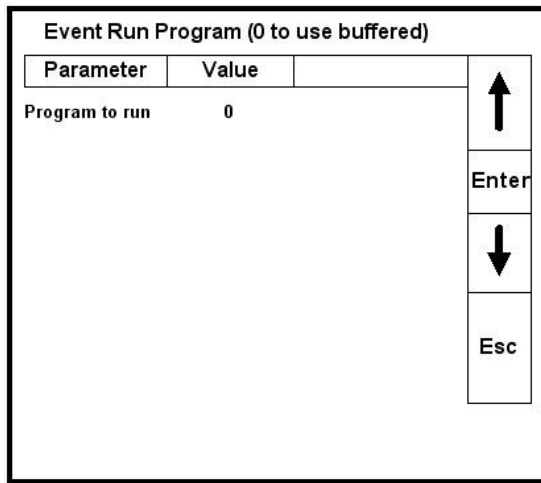

Pressing the **Enter** key takes you to a screen labeled *Event Run Program (0 to use buffered)*.

This is used to start a program stored in the 9200, by contact closure between terminals 21 (Digital In Com) and 17 (Digital In 1). The value entered at program to run will start with contact closure.

Pressing **Enter** pops up the Current Value Screen, showing the current value in the Series 9200. To make an adjustment, enter the program number, using the numeric keypad and press the **Enter** key. This returns you to the original Event Run Program Screen that now shows the new program number that you have entered. If you do not wish to make the change simply press the **Esc** key which takes you back to the Event Run Program Screen with NO change being made to the Event Run Program.

### Zone / Load TC Setup

Pressing the **Enter** key takes you to the following screen.

This screen is used to set up Load, Monitor Thermocouples. It is normally used in conjunction with an ADAM Module to provide information from the Load Thermocouples. There are three modes of operation for Load TC Enable. They are Off, On and On + Alarm. To set the mode on Load TC Enable, highlight it and press **Enter**, this will open a new window, use the blue up and down arrows to highlight the desired mode then press **Enter**. This will enter the selected mode and return you to the Load TC Screen. By activating a thermocouple, no conditional soak will start unless the temperature is with the default wait limits of the selected thermocouple(s).

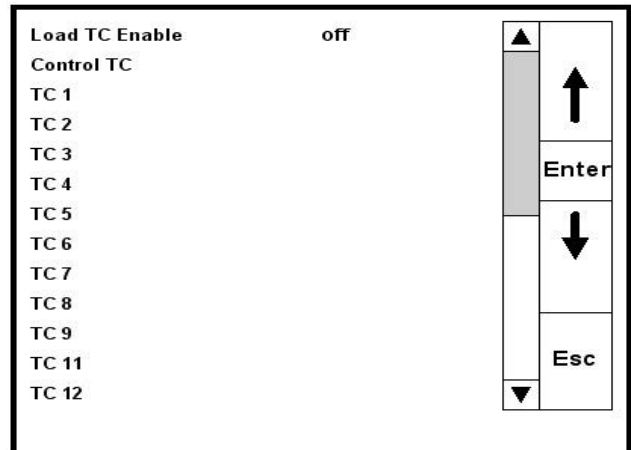

To activate one or more of the thermocouples, use the blue up and down arrows to highlight the desired thermocouple then press **Enter**. This will activate, or deactivate the selected thermocouple.

Port Setup

**Warning:** Changes to this screen should not be made without consulting SSi at 513-772-0060.

Highlighting this menu selection and pressing the **Enter** key moves you to the Port Setup Screen.

Parameter	Value
Host 232 Baud	TPC-642S
Host 232 Mode	Modbus
Host 485 (3,4) Baud	19200
Host 485 (3,4) Mode	Modbus
Host 485 (3,4) Address	1
Slave 1 (5,6) Baud	19200
Slave 1 (5,6) Mode	Modbus
Slave 2 (22,23) Baud	9600
Slave 2 (22,23) Mode	ADAM

These values can be changed by using the up and down arrow keys to highlight your selection, press the **Enter** key. A selection of communication protocols is displayed. Make your selection and press the **Enter** key. The **Cancel** key takes you back to the previous screen without changes being made.

Instrument Setup

**WARNING:** This screen should not be changed without consulting SSi at 513-772-0060.

Highlighting this entry and pressing the **Enter** key takes you to a two-level screen. The first level allows you to select the instrument to setup. To highlight the desired instrument use the first set of blue up and down arrow keys and then press **Enter** key. This list of controllers includes the following **Atmosphere**

**Controllers:**

- SSi AC20
- Yokogawa 750
- Honeywell UDC3300
- Dualpro 1 Modbus
- Dualpro 2 Modbus
- Dualpro 1 MMI
- Dualpro 2 MMI
- Eurotherm 2404
- Eurotherm 2500
- Carbpro v3.5
- Carbpro v3.0
- CarbPC
- 9200 Loop 1
- IR Base

This list of controllers includes the following **Temperature Controllers:**

- SSi 7EK
- Yokogawa 750
- Honeywell UDC3300

- Dualpro 1 Modbus
- Dualpro 2 Modbus
- Dualpro 1 MMI
- Dualpro 2 MMI
- Eurotherm 2404
- Eurotherm 2500
- Unipro v3.5
- Unipro v3.0
- Carbpro v3.5 Slave
- Carbpro v3.0 Slave
- 10Pro
- DualPro IN C
- 9200 LP1
- 9200 LP2
- 9200 LP3
- 9100 LP1
- Eurotherm 2704 lp1
- Eurotherm 2704 lp2
- Eurotherm 2704 lp3
- VC BASE 1
- VC BASE 2
- VC BASE 3
- VC BASE 4
- AIPC
- SSi 7SL
- AEC Flow Board
- HW UMC800 Lp1

This list of controllers includes the following **Event Controllers**:

- SSi AC E
- Yokogawa 750E
- Mod Mux
- Dualpro E Modbus
- Dualpro E MMI
- Carbpro E v3.5
- Carbpro E v3.0
- Eurotherm 2500
- SSi 8-8
- 9200E
- Micrologox PLC

Selecting, for example, the SSi AC20, the following screen is shown.

Using the blue up and down arrow keys highlight the desired selection and press the **Enter** key. This returns you to the previous screen and shows you the instrument that you have chosen and then will allow you to make some changes per the parameters shown. An address of 0 is a non-defined instrument.

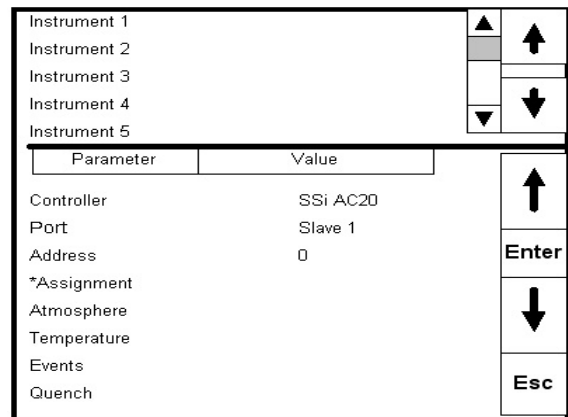



Pressing the **Esc** key will return you to the Menu Screen.

Zone Assignments

**WARNING:** This screen should not be changed without consulting SSi at 513-772-0060.

The zone assignment feature allows the SERIES 9200 program to change set points on all instruments of a multi-zone furnace. The SERIES 9200 has up to five (5) temperature and atmosphere zone assignments available. The SERIES 9200 programmer looks for appropriate zone assignments whenever a set point is to be sent to the atmosphere or temperature controller. The temperature set point is sent to every instrument number in the temperature zone assignment.

If the *ZONE\_OFF* (Zone Offset) opcode had been used in the program, the set point sent to the specified zone instrument would have the offset added. For example, a 3-zone pit furnace where the bottom zone usually has a higher set point. The middle zone and the top zone usually have a lower set point. The bottom zone temperature controller is assigned to zone 1, the middle temperature controllers to zone 2, and the top zone controller to zone 3.

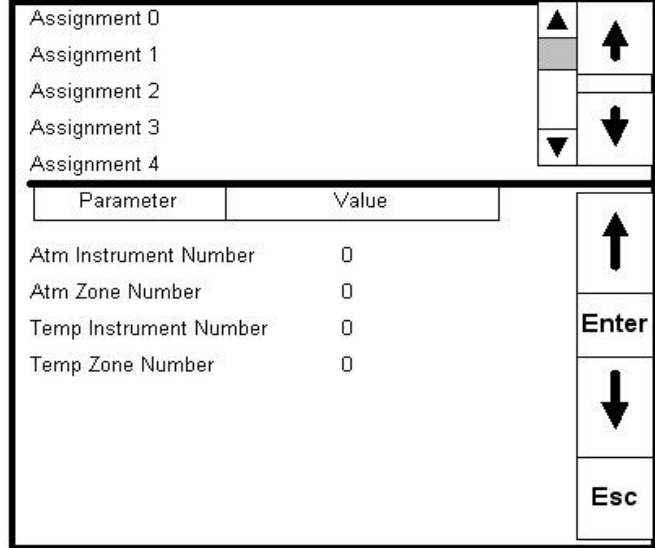

If the first three steps of a program are as shown below, then the bottom zone set point is 1725, the middle zones are 1750, and the top zone is 1800.

Step	opcode	Temperature	Atmosphere	Option
1	<i>ZONE_OFF</i>	50		1
2	<i>ZONE_OFF</i>	25		3
3	<i>SETPT</i>	1750		

The first step sets the offset for zone 1 to -25 degrees; therefore, the bottom zone controller would be sent a set point of 1725 when step 3 is executed. Likewise step 2 sets the offset for zone 4 to 50 degrees. The top zone then receives a set point of 1800. The middle zone controller would receive the 1750. The temperature controller displayed on the Status Display is instrument #2. If instrument #2 were the top zone controller then the Status Display would show the 1800-degree set point.

When using the multi-zone offset feature, the atmosphere and temperature controller assigned as instruments 1 and 2 should be in zones that will not be offset.

Furnace Setup

Parameter	Value
PVT Type	% Carbon
Nitrider Mode	N/A
H2 Cell Type	N/A
H2 RS-232 Comms	N/A
Temp Display	N/A
LP3 Control	N/A
N2 Value	N/A
NH3 Value	N/A
D. A. Value	N/A
Aux. Value	N/A
Temperature Mode	F.
Programmer	

When highlighted, press the **Enter** key. This takes you to the Furnace Setup Screen containing the following options. When PVT Type is highlighted and the **Enter** key is pressed the following choices appear: Highlighting your choice and pressing the **Enter** key returns you to the Furnace Setup Screen with your new choice

% Carbon
Dew Point
% O2 (Oxygen)
Millivolts
Multi-loop
Vacuum
IR + Probe
Nitrider
% Carbon with dual temp
Cascade Control

appearing in whatever parameter that you had selected.

Pressing the **Esc** key returns you to the Menu Screen.

Default Wait Limits

Pressing the **Enter** key takes you to the Wait Limit Setup Screen.

Parameter	Value
Temperature Wait Limit	15 °
Atmosphere Wait Limit	0.10 % Carbon

The wait limits are used in the recipe programming. A wait limit allows the program to move to the next step once the process variable (or the actual furnace) has reached the default wait limits that are indicated on this screen.

Highlighting your choice to be changed and pressing the **Enter** key moves you to a numeric keypad that allows you to enter a new value by touching the appropriate keys. Once you have made the change pressing the **Enter** key takes you back to the previous screen. Once again pressing the **Esc** key takes you back to the previous screen without making the changes.

Pressing the **Esc** key returns you to the Menu Screen.

Furnace Name

Highlighting this selection and pressing the **Enter** key displays the following Furnace Name Screen.

Parameter	Value
Furnace Name	??????????????
PV1 Name	Temperature
PV2 Name	Temperature
PV3 Name	Temperature

Highlighting Furnace Name and pressing the **Enter** key displays an alphanumeric keyboard. Type the furnace name that you wish to be displayed. Pressing the **Enter** key returns you to the previous screen  
Furnace Name

Pressing the **Esc** key returns you to the Menu Screen.

Alarm Setup

Highlighting this entry and pressing the **Enter** key takes you to a two-level screen. The first level allows you to select the alarm. The second level scrolls through parameters.

Parameter	Value
Setpoint	
Alarm Type	
Hysteresis	

A numeric keypad is used to enter the Alarm set point, pressing **Enter** after selecting the value.

Using the blue up and down arrow keys, select *Alarm Type* press the **Enter** key. Using the blue up and down arrow keys select the alarm type from the top and bottom choices.

- |                            |                         |
|----------------------------|-------------------------|
| The top choices are:       | The bottom choices are: |
| Process High               | PV 1 Value              |
| Process Low                | PV 2 Value              |
| Band, Normally Open        | PV 3 Value              |
| Band, Normally Closed      | Input 1 Value           |
| Deviation, Normally Open   | Input 2 Value           |
| Deviation, Normally Closed | Input 3 Value           |
|                            | P01 Value               |
|                            | P02 Value               |
|                            | P03 Value               |

After highlighting your choice press the **Enter** key. This returns you to the previous screen. You should observe the choice that you made for *Alarm Type* displayed. Using the blue up and down arrow keys highlight *Hysteresis* and press the **Enter** key. A numeric pad is displayed to allow you to enter a value. Press the applicable numeric keys and press **Enter**. You should be returned to the original Alarm Setup Screen. If you are configuring more than one alarm, follow the above instructions for each alarm that you are configuring.

Pressing the **Esc** key returns you to the Menu Screen.

Relay Assignments

Pressing the **Enter** key moves you to the following screen.

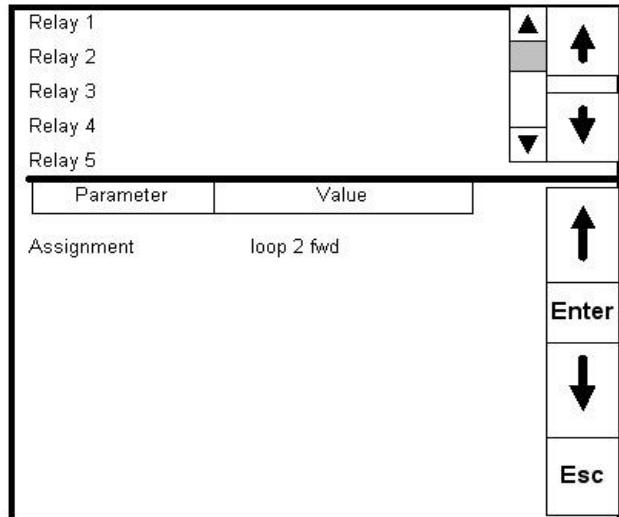

Highlighting the relay that you wish to assign and pressing the **Enter** key takes you to a screen that has the following choices:

- Loop 1 fwd
- Loop 1 rev
- Loop 2 fwd
- Loop 2 rev
- Loop 3 fwd
- Loop 3 rev
- Programmer alarm
- Alarm 1
- Alarm 2
- Alarm 3
- Event 0 through Event 15
- Burn off
- IN 1 Relay SP A
- IN 1 Relay SP B
- IN 1 Relay SP C
- IN 2 Relay SP A
- IN 2 Relay SP B
- IN 2 Relay SP C
- IN 3 Relay SP A
- IN 3 Relay SP B
- IN 3 Relay SP C

From these choices, you can select which function you wish assigned to Relays 1 through 8.

Pressing the **Esc** key returns you to the Menu Screen.

Relay Set Points

Relay On/Off Setpoints	
Parameter	Value
Relay ON SP for IN1 A	0
Relay OFF SP for IN1 A	0
Relay ON SP for IN1 B	0
Relay OFF SP for IN1 B	0
Relay ON SP for IN1 C	0
Relay OFF SP for IN1 C	0
Relay ON SP for IN2 A	0
Relay OFF SP for IN2 A	0
Relay ON SP for IN2 B	0
Relay OFF SP for IN2 B	0
Relay ON SP for IN2 C	0
Relay OFF SP for IN2 C	0
Relay ON SP for IN3 A	0

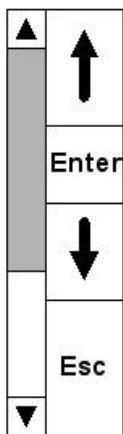

Highlighting the above menu option and pressing the **Enter** key, moves the operator to the screen below.

Highlighting one of the choices below allows the operator to change the value of the highlighted selection using the numeric keypad that pops up.

These values are only valid if the assigned relay has been assigned IN? Relay SP ? (where? equals actual value) on the Relay Assignment Screen.

Pressing the **Esc** key returns you to the Menu Screen.

Analog Input Setup

Pressing the **Enter** key takes you to a two-zone screen with the top zone showing the three inputs. Pressing the blue up and down keys highlights one of the inputs. Pressing the **Enter** key takes you to a menu of parameters that can be assigned to any of the three inputs. Included are thermocouple types, voltages, and current inputs.

The lower zone of the Input Setup Screen contains a table.

Parameter	Value
TC Type	S
Filter Time	0
Initial Scale	0
Full Scale	3000
Decimal Point Location	0
Open TC	Up scale
Input offset	0
Use curve	0

Selecting the input type of Inputs 1 through 3 automatically places that parameter in the first table cell (TC Type). Using the blue up and down arrow keys to highlight the table cell below the parameter TC Type, and pressing the **Enter** key brings up a numeric keypad that allows you to type in the parameter that is appropriate. If no parameter is necessary simply move the highlight down to the next parameter and enter that if required. Continue until all values associated/required by the input type have been entered. Pressing the **Esc** key takes you back to the Configuration Menu.

*NOTE: See the following list of Input Selections*

Input type selections for the Series 9200 -

Input Type Options	T/C's B, C, E, J, K, N, NNM, R, S, T
	781.25, 195.3125, 25, 12.5, 2.5 and 1.25 Volts
	78.125, 19.53125 Millivolts
	4 - 20 mA (124 Ohm precision shunt required)
	25 Volts (Requires internal jumper)
	12.5 Volts (Requires internal jumper)
	781.25 Millivolts (Requires internal jumper)
	195.3125 Millivolts (Requires internal jumper)

Analog Output Setup

Pressing the **Enter** key takes you to a page similar to the input setup with the exception that these are outputs, not inputs.

Pressing the **Enter** key when Output 1 is highlighted displays a screen with many parameters listed that could be assigned to Output 1. Remember that this is **NOT** control output, but an auxiliary output. For example you can re-transmit PV1 (Process Variable 1 - %C) to a chart recorder or an analog input board in a PLC. Pressing the **Enter** button assigns whichever parameter you have highlighted as the value for the assignment parameter.

**Model 9200 Programmable Dual-loop Controller**

---

The blue up and down arrow keys highlight either Output 1 or Output 2. Pressing the **Enter** key takes you to a list of outputs. Selecting an output returns a screen similar to the one below.

Parameter	Value
Assignment	
Offset	
Range	
Current Selection	

Pressing the **Esc** key returns you to the Configuration Menu.

Passcode and Alarm

Highlighting *Passcode and Alarm* and pressing the **Enter** key takes you to the following screen:

Parameter	Value
Level 1 Code	1
Level 2 Code	2
Web Level 1 Code	111
Web Level 2 Code	222
No Alarm	Contact is Open (NO)
Web Change Enable	1

Alarm Text Setup	
Alarm 0	User Alarm 0
.....	.....
Alarm 99	User Alarm 99

The values shown in the above table are the default values. The parameter *NO ALARM* means that if there is no controller alarm, the controller alarm relay is NO. Scroll down until *NO ALARM* is highlighted. Press **Enter**. On the numeric keypad use a **1** and press the **Enter** key to change the state of the relay to *Contact is Closed*, and use a **0** and press the **Enter** key to change the state of the relay to *Contact is Open*. This allows the operator to assign the controller alarm as a NC contact such as a 1400° F alarm.

When highlighting a parameter and pressing the **Enter** key a numeric keypad is displayed allowing you to enter your value. Enter that value using the touch-screen keypad and press the **Enter** key. The change will be made. Press the **Esc** key to return to the Configuration Menu.

Alarm 0 through 99

Highlighting *Alarm ??* and pressing the **Enter** key displays an alphanumeric keyboard. Type the alarm text that you wish to be displayed. Pressing the **Enter** key returns you to the previous screen Passcodes. These text messages will be displayed on the Loops Screen when generated by the program and active.

IP Address

**NOTE:** This screen option is for changing *the controller's IP address*. If you need to change the *IP address of the Touch Screen*, see the instructions in Appendix A of the Touch Screen Manager manual, available at [www.supersystems.com](http://www.supersystems.com).

Highlighting *IP Address* and pressing the **Enter** key displays the following screen.

**Model 9200 Programmable Dual-loop Controller**

Parameter	Value
IP Address 1	192
IP Address 2	168
IP Address 3	1
IP Address 4	200
IP Address Mask 1	255
IP Address Mask 2	255
IP Address Mask 3	255
IP Address Mask 4	0
IP Address Gateway 1	192
IP Address Gateway 2	168
IP Address Gateway 3	1
IP Address Gateway 4	1

Highlighting whichever parameter needs to be entered and pressing the **Enter** key displays a numeric keypad that can be used to enter the required value. Pressing the **Esc** key returns you to the Configuration Menu.

The default IP Address is: 192.168.0.200  
 The default IP Address Gateway is: 192.168.1.1

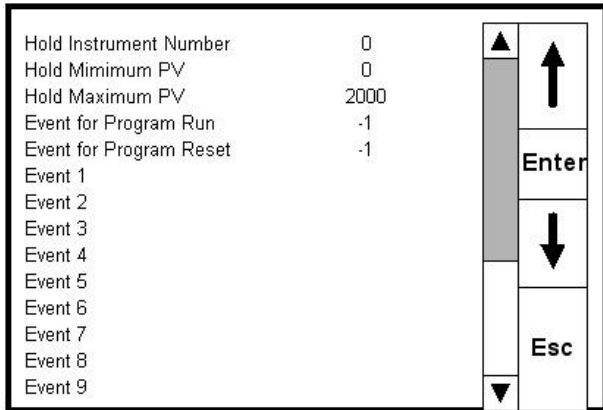

Event Control

Pressing the **Enter** key makes the following screen appear.

*Hold Instrument Number* defines the Slave Instrument to be placed in hold (normally used with Soak) if the Process Variable goes below the value entered in *Hold Minimum PV*, or above *Hold Maximum PV*.

Highlighting your choice to be changed and pressing the **Enter** key moves you to a numeric keypad that

allows you to enter a new value by touching the appropriate keys. Once you have made the change pressing the **Enter** key takes you back to the previous screen. Once again pressing the **Esc** key takes you back to the Event Control Screen without making the changes.

*Event for Program Run* defines which event contact will start the program identified on the Event Run Program Setup Screen.

*Event for Program Reset* defines which event contact will reset the program currently running.  
**NOTE: this will only reset the program, all set points, events, etc will remain in their last state.**

Valve Setup – USED ONLY IN THE NITRIDING VERSION

Pressing the **Enter** key makes the following screen appear.

Parameter	Value
Filter Factor	0
9200 Program Alarm	off
9200 Alarm 1	off
9200 Alarm 2	off
9200 Alarm 3	off
Digital Input 0	off
Digital Input 1	off
Digital Input 2	off
Digital Input 3	off
Digital Input 4	off
Digital Input 5	off
Digital Input 6	off

Valve Inputs –USED ONLY IN THE NITRIDING VERSION

Programmer Setup

Pressing the **Enter** key makes the following screen appear.

This screen is used to restore the 9200 Factory Defaults. This is accomplished by pressing the **Factory Defaults** button. A new screen, Set Factory Defaults will appear, press Yes. This will restore settings.

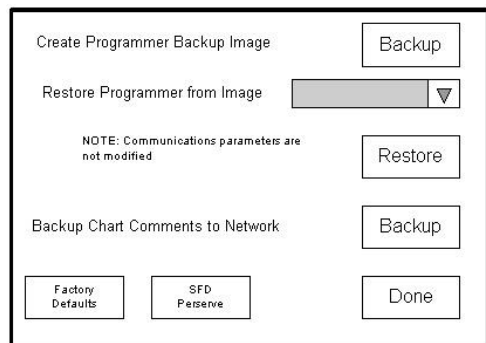

You can backup the NOTES from the SD Charting to the network.

Pressing **Done** will return you to the Main Menu.

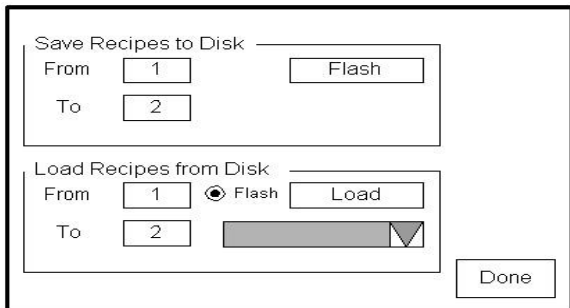

Recipe Transfer

*Note: Any Configuration / Setup information previously entered may be lost*

User Calibration

Highlighting *User Calibration* and pressing the **Enter** key takes you to the following screen.

Pressing the **Edit** button displays a numeric keypad allowing you to change the Cold Junction value. After enter the new Cold Junction value you must press **Calibrate**. Pressing the **Calibrate** key stores the appropriate value. Pressing the **Done** will return you to the User Calibration Screen.

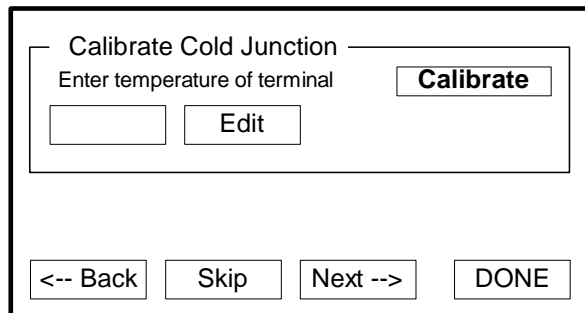



The current value is displayed directly above the bottom row of buttons as Current CJ value: XX.X ° F.

Pressing the **Next ->** key displays the following screen.

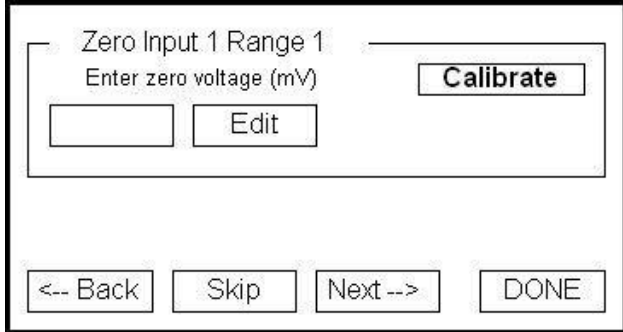

Pressing the **Edit** button displays a numeric keypad allowing you to change the Zero Input 1 range value. Normally terminals 31 and 32 are shorted for this step.

After entering the new Zero Input value you must press **Calibrate**. Pressing the **Calibrate** key stores the appropriate value. Pressing the **Done** will return you to the User Calibration Screen.

The current value is displayed directly above the bottom row of buttons as Current Input 1 value: XX.X

UV.

Pressing the **Next ->** key displays the following calibration screen:

Pressing the **Edit** button displays a numeric keypad allowing you to change the Span Input 1 range value. Normally terminals 31(-) and 32(+) have 2000 mV applied for this step.

After entering the new Span Input value you must press **Calibrate**. Pressing the **Calibrate** key stores the appropriate value. Pressing the **Done** will return you to the User Calibration Screen.

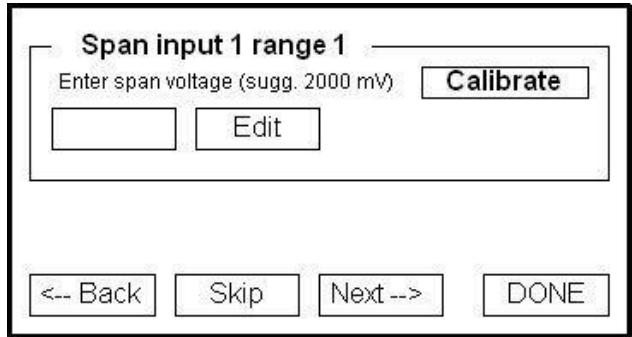

The current value is displayed directly above the bottom row of buttons as Current Input 1 value: XX.X UV.

Pressing the **Next ->** key displays the following calibration screen:

Pressing the **Edit** button displays a numeric keypad allowing you to change the Zero Input 2-range value. Normally terminals 29 and 30 are shorted for this step.

After entering the new Zero Input value you must

press **Calibrate**. Pressing the **Calibrate** key stores the appropriate value. Pressing the **Done** will return you to the User Calibration Screen.

The current value is displayed directly above the bottom row of buttons as Current Input 2 value: XX.X UV.

Pressing the **Next ->** key displays the following calibration screen:

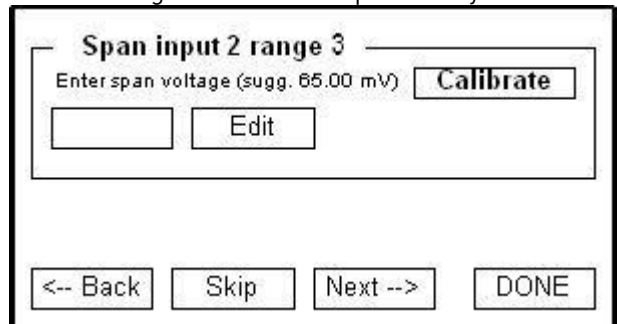

Pressing the **Edit** button displays a numeric keypad allowing you to change the Span Input 2-range value. Normally terminals 29(-) and 30(+) have 17.500 mV applied for this step. After entering the new Span Input value you must press **Calibrate**. Pressing the **Calibrate** key stores the appropriate value. Pressing the **Done** will return you to the User Calibration Screen.

The current value is displayed directly above the bottom row of buttons as Current Input 2 value: XX.X UV

Pressing the **Next ->** key displays the following calibration screen:

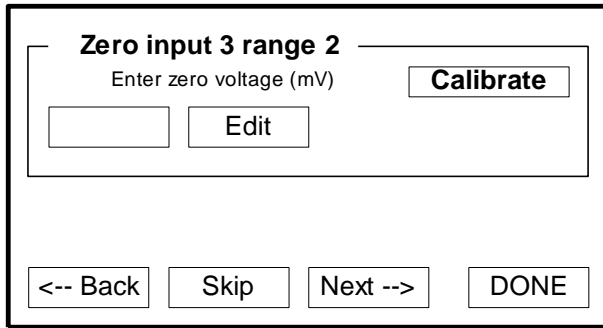

Pressing the **Edit** button displays a numeric keypad allowing you to change the Zero Input 3range value. Normally terminals 27 and 28 are shorted for this step.

After entering the new Zero Input value you must press **Calibrate**. Pressing the **Calibrate** key stores the appropriate value. Pressing the **Done** will return you to the User Calibration Screen.

The current value is displayed directly above the bottom row of buttons as Current Input 2 value: XX.X

UV.

Pressing the **Next ->** key displays the following calibration screen:

Pressing the **Edit** button displays a numeric keypad allowing you to change the Span Input 3range value. Normally terminals 27(-) and 28(+) have 65.000 mV applied for this step. After entering the new Span Input value you must press **Calibrate**. Pressing the **Calibrate** key stores the appropriate value. Pressing the **Done** will return you to the User Calibration Screen.

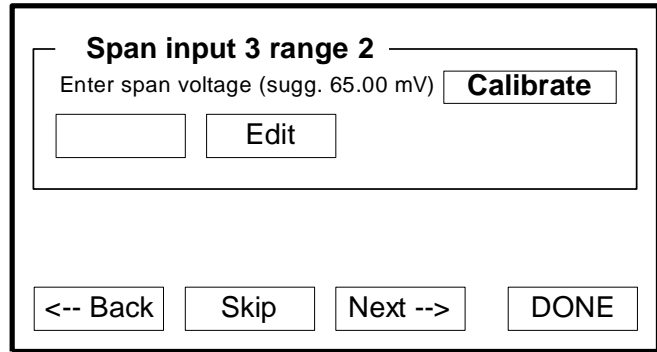

The current value is displayed directly above the bottom row of buttons as Current Input 3 value: XX.X UV

Pressing the **Next ->** key displays the following calibration screen:

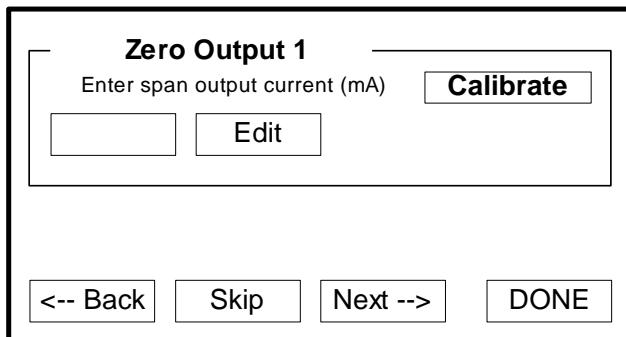

Pressing the **Edit** button displays a numeric keypad allowing you to change the Zero Output 1 value. Measured at terminals 24(-) and 25(+) for this step. After entering the new Zero Output value you must press **Calibrate**. Pressing the **Calibrate** key stores the appropriate value. Pressing the **Done** will return you to the User Calibration Screen.

Pressing the **Next ->** key displays the following calibration screen:

Pressing the **Edit** button displays a numeric keypad allowing you to change the Span Output 1 value. Measured at terminals 24(-) and 25(+) for this step. After entering the new Span Output value you must press **Calibrate**. Pressing the **Calibrate** key stores the appropriate value. Pressing the **Done** will return you to the User Calibration Screen.

Pressing the **Next ->** key displays the following calibration screen:  
 Pressing the **Edit** button displays a numeric keypad allowing you to change the Zero Output 2 value.

value. Measured at terminals 26(-) and 25(+) for this step. After entering the new Span Output value you must press **Calibrate**. Pressing the **Calibrate** key stores the appropriate value. Pressing the **Done** button will return you to the User Calibration Screen.

Pressing the **Next ->** displays a screen that indicates that the calibration process is complete. Pressing the **Done** key at the bottom right of the screen takes you back to the Configuration Menu.

Full Calibration

Used by SSI personnel.

Set Menu Security

Pressing the **Enter** key moves you to the screen below.

Menu Item	Security Level
Program Edit	Supervisor
CO Factor Entry	Operator
Burnoff	Operator
Auxiliary Instruments	Operator
Auxiliary Analog Inputs	Operator
Shutdown	Operator
Adjust Date and Time	Supervisor
Slave Communications	Supervisor
Backup Compressed Data	Supervisor
Manual Event Control	Supervisor
Probe Burnoff Setup	Supervisor
PID Loop Setup	Supervisor
Event Run Program Setup	Supervisor

Highlighting a specific screen (using the blue up and down arrows) and pressing the **Enter** key changes the displayed Security Level of the highlighted screen.

The additional items on the above screen are as follows:

Zone /Load TC Setup	Supervisor
Port Setup	Administrator
Instrument Setup	Administrator
Zone Assignments	Administrator
Furnace Setup	Administrator
Default Wait Limits	Administrator
Furnace Name	Administrator
Alarm Setup	Administrator
Relay Assignments	Administrator
Relay Setpoints	Administrator
Analog Input Setup	Administrator

Measured at terminals 26(-) and 25(+) for this step. After entering the new Zero Output value you must press **Calibrate**. Pressing the **Calibrate** key stores the appropriate value. Pressing the **Done** will return you to the User Calibration Screen. Pressing the **Next ->** key displays the following calibration screen:

Pressing the **Edit** button displays a numeric keypad allowing you to change the Span Output 2

Analog Output Setup	Administrator
Passcode and Alarm	Administrator
IP Address	Administrator
Event Control	Administrator
Valve Setup (Nitriding Only)	Administrator
Valve Inputs (Nitriding Only)	Administrator
Programmer Setup	Administrator
Recipe Transfer	Administrator
User Calibration	Administrator
Full Calibration	Operator
Set Menu Security	Operator
Read/Write Raw Data	SSi
Tuning Assistant	Operator
Curve Entry	Operator
Alternate PID Setup	Operator
Analog Input Board Setup	Operator
AI Board Calibration	Operator
ADAM Correction	Operator
Aux SP Configuration	Operator

The four Security Levels available are:

Operator	Level 1	Full access to the indicated screen
Supervisor	Level 2	Access to screen is limited by Passcode (Passcode and Alarm Screen)
Administrator	Level 3	Access to screen is limited by Passcode (Passcode and Alarm Screen)
SSi	Level 4	Used by SSi personnel for configuration purposes

Read/Write Raw Data

Used by SSi personnel.

Tuning Assistant

The Tuning Assistant menu option will allow the user to automatically generate the PID loop settings for the control loops in the 9200 controller.

*Note: The four buttons at the bottom of the screen: **Accept Under Damped, Accept Critically Damped, Accept Over Damped, and Accept PI** will be inaccessible until some PID settings are loaded into the PID settings list above the buttons. The **Cancel** button in the bottom right of the screen will close down the screen. The user can select the loop to use from the drop down list next to "Loop" at the top of the screen. The loop choices are: 1, 2, or 3. This will select the specific loop to perform the auto tune on.*

The user can select the tuning option from the "Tuning" section on the top left of the screen. The choices are: **Relay** and **Lim. Relay** (Limited Relay). This option will allow the user to limit the output value while the controller is controlling the furnace. Normal operation will typically use 100 % output. When the limited relay option is selected, the "Tuning Delta:" label and the **Edit** button will be displayed. When the **Relay** option is selected, the "Tuning Delta:" label and the **Edit** button will be hidden. The "Tuning Delta:" value will be the amount to limit the controller by. Pressing the **Edit** button will display the numeric keypad, which will allow the user to enter the limiting value.

The current value will be displayed at the top of the screen. Enter the new value and press the **Enter** button to set the value. Pressing the **Esc** button will cancel the change.

The "Conservative" option will allow the user to minimize, if not remove, the possibility for an overshoot of the setpoint. If a small overshoot is acceptable, leave the "Conservative" checkbox unchecked. If, however, no overshoot is desired, then checking the "Conservative" checkbox will accomplish this.

Pressing the **Start** button will begin the auto tune process. *Note: The process may take a few seconds to start.* The "Idle" line will change to

**Tuning - Pointer:51 PV:1289/SP:1300**

process variable value and the setpoint.

*Note: The **Start** button will be disabled while the calibration is running.* Pressing the **Abort** button will abort the process. If the **Cancel** button is pressed while a calibration is running, a message box will be displayed confirming

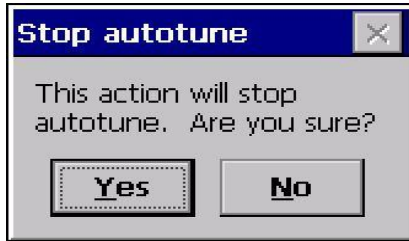

Pressing the screen. When the populated underneath

	Underdamp	Crit Damp	Overdamp	PI Only
P	1.2	1.8	2.4	1.3
I	3.69	1.84	1.23	1.10
D	0.10	0.13	0.13	

Critically Damped set of values, press the **Accept Critically Damped** button. The under damped values will reach the setpoint faster, but there will be more overshoot involved. The over damped values will work to minimize the overshoot, but it will be slower than the under damped values. The critically damped values are considered the "optimum" values because they are a balance between the under damped and over damped values with regards to time and overshoot. The PI values are just the proportional band and the reset value (the *P* and the *I* from *PID*). This could be applicable in an atmosphere loop, where the rate won't have much effect.

Once a set of values has been accepted, the user can press the **Cancel** button to exit the screen. The accepted values can be viewed on the *PID Loop Setup* menu option. *Note: Once the screen is closed out, the PID settings values will be lost.* To populate these values again, another calibration routine will need to be run.

Curve Entry

Pressing the **Enter** key makes the following screen appear.

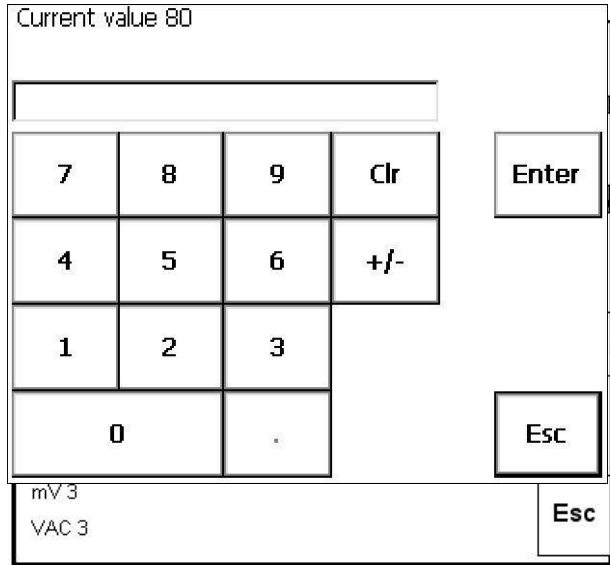

display the calibration process for the auto tune. The line will display a pointer value, along with the

**Yes** button will stop the auto tune calibration and exit. The **No** button will cancel the abort process. calibration is finished, the PID settings list will be with suggested values and the four buttons will be enabled. The line above the PID settings list

will read "Idle" again as well.

The user has the option to select only one of these sets of values: either the Under Damped set, the Critically Damped set, the Over Damped set, or the PI set. To select the set of values, press the corresponding button. For example, to select the

This screen is used to install custom curve information. It is normally used in Vacuum or Nitriding Furnace applications, and only should be used after contacting SSi personnel at 513-772-0060.

Pressing **Esc** will return you to the Main Menu.

Alternate PID Setup

Pressing the **Enter** key makes the following screen appear.

This screen is used to enable up to 16 sets of alternate PID's for control purposes. It is implemented with the PID Select Opcode in the program.

By using the upper blue up and down arrow, you can highlight the PID set to be modified, then press **Enter** to display the parameters associated with that PID set. By using the lower blue up and down arrows (above and below the **Enter**) you can highlight the desired parameter. Once highlighted, pressing **Enter** will display a numeric keypad, with the current value displayed. By selecting the new value and **Enter**, you have entered the new desired value. Pressing **Esc** will return you to the PID Setup Screen. Pressing **Esc** will return you to the Main Menu.

PID 1		▲	▲
PID 2			▲
PID 3			▼
PID 4		▼	▼
PID 5			▼
Parameter	Value		
Proportional Band	-0.1	▲	
Reset	0.00		Enter
Rate	0.00		▼
Integral Preset	0		
High Limit	100		
Low Limit	-100		Esc

Analog Input Board Setup

Used by SSi personnel.

AI Board Calibration

Used by SSi personnel.

ADAM Correction

The ADAM module offset correction menu option gives the user the ability to offset any input on any ADAM module for up to five ADAM modules. There are eight inputs per module. The offset can be in degrees + or -, and it is typically used to compensate for incorrect T/C wires. The offsets are entered and displayed on the screen without decimal points. For example, an offset of **255** would actually be an offset of **25.5** degrees +, and an offset of **-85** would be an offset of **8.5** degrees -.

Parameter	Value	▲	▲
Mod. 1, Input 1	500		▲
Mod. 1, Input 2	-500		
Mod. 1, Input 3	0		
Mod. 1, Input 4	-255		Enter
Mod. 1, Input 5	-425		▼
Mod. 1, Input 6	0		
Mod. 1, Input 7	0		
Mod. 1, Input 8	250		
Mod. 2, Input 1	25		
Mod. 2, Input 2	0		
Mod. 2, Input 3	0		
Mod. 2, Input 4	-36		Esc
Mod. 2, Input 5	0	▼	

Aux SP Configuration

Parameter	Value	
Retrans to Slave 1	Loop 1	↑
Retrans to Slave 2	Loop 2	
Retrans to Slave 3	Off	
Setpoint Offset Sl 1	50	Enter
Setpoint Offset Sl 2	0	
Setpoint Offset Sl 3	0	
Setpoint Delay Sl 1	15	↓
Setpoint Delay Sl 2	0	
Setpoint Delay Sl 3	0	
		Esc

This menu option allows for up to three slave instruments to have the setpoint retransmitted from one of the three control loops. This menu option is typically used to retransmit an alarm setpoint value to an overtemp controller. The “Retrans to Slave 1”, “Retrans to Slave 2”, and “Retrans to Slave 3” menu options each have four options to select: **Off**, **Loop 1**, **Loop 2**, or **Loop 3**. These options will allow the user to select which, if any, values to retransmit to the selected slave instrument. The “Setpoint Offset Sl 1”, “Setpoint Offset Sl 2”, and “Setpoint Offset Sl 3” menu options can be a number between **-32767** and **32767**. These options will allow the user to set the destination

offset for the selected slave instrument. The “Setpoint Delay Sl 1”, “Setpoint Delay Sl 2”, and “Setpoint Delay Sl 3” menu options can be a number between **-32767** and **32767**. These options will allow the user to set the delay, in seconds, before the setpoint is retransmitted to the selected slave instrument.

Overview

The program format used in the SERIES 9200 provides a simple but powerful recipe language for controlling the heat-treat process. The SERIES 9200 can store up to 300 programs of twelve steps each. Each step consists of an opcode that defines what is done at this step. The step can also contain atmosphere, temperature, and option data.

This enhanced step approach provides for shorter programs. For example, a complete boost /diffuse program can be done in twelve steps.

The programmer also has alarm capability that can be turned on during a program to monitor deviations and high and low limits while the program is running.

Program Editing

The Program Edit Display is accessed through the Menu key on the Default Display Screen. Pressing the **Menu** key displays a screen that contains the configuration items that all personnel are allowed to perform. On that screen, running down the right side are five buttons. Below the blue down arrow key is the **Login** key. Pressing this key displays a numeric keypad that allows you to enter the passcode to get to the

S	Opcode	Tmp	Atm	Option
1	SETPT	1700		wait
2	SETPT	1700	1.00	wait
3	SOAK			2:30
4	EVT_OUT			3-ON
5	SETPT	1600		wait
6	DELAY			3
7	EVT_OUT			3-OFF
8	SETPT	1600		wait
9	SOAK			1:00
10	EVT_OUT			1-ON
11	ALARM			1
12	EVT_OUT			1-OFF

configuration level (default as shipped from SSi is the number 2). Entering the password and then pressing the **Enter** button displays the many configuration options; the first option is *Program Editing*. Highlighting this parameter and pressing the **Enter** key displays a numeric screen pad that asks you to enter the number of the program that you wish to edit. Pressing that recipe number and then pressing **Enter** displays that particular recipe. You may have to CLEAR the recipe number that is shown in the display box if the number of the recipe to be edited was not the last recipe run on the system. Press the **Clr** button on the numeric keypad and then enter the number for the recipe that you wish to edit. To edit a step in the recipe, using the up and down arrow keys, highlight the step that you wish to edit and press

the **Enter** key.

Highlighting the parameter that you wish to edit and pressing the **Enter** key takes you to the appropriate menu, either that of the opcode choices, or a numeric keypad to allow you to change the time. After making the change, press the **Set** button twice to have the change take place. This returns you to the Program Edit Screen. At this time you can choose to save the program as the same number, or if you have edited the program to save the program as a new recipe number, make the choice at this time and press the **Save** button. This is a quick way to make new recipes using an already existing recipe and changing only those steps that need to be changed.

Pressing the **Cancel** button on either display takes you back to the Edit Screen without making any changes.

Parameter	Value
Opcode	SOAK
Time (hh:mm)	1:00



Programmer Description

The SERIES 9200 series Atmosphere/Temperature Recipe Programmer provides a convenient operator interface and recipe programmer.

The programmer uses enhanced opcodes that reduce the number of steps required for a program. Each step consists of an opcode, a temperature value, an atmosphere value, and an option value. The opcode determines how and if each of the three values are used.

Opcodes

*NO-OP* This no operation code does nothing and is used as a place hold on programs that are less than 12 steps.

*ALARM* This alarm function is used to notify the operator that an operation is complete or that a manual action is required. By use of the Passcode and Alarm Screen, up to 99 User Alarms can be assigned, with a short text on each. Displayed during an active Alarm Condition. The program waits until the alarm is acknowledged to proceed.

*ATM\_INQ* the atmosphere inquiry is used to wait for the actual atmosphere to reach the value specified in the atm (atmosphere) field.

The options are:

- wait, reach within band;
- wait up, reach or exceed the set point;
- wait down, reach or be less than the set point.

The default band can be set under the Configuration Menu and is typically 10 (i.e. 0.10 percent carbon).

- The *SET\_WAIT* opcode will change the band limit
- The *LIMIT* opcode immediately following this opcode sets a time limit on the wait.
- A *BRANCH* opcode immediately following this opcode can be used to change the program flow based on the inquiry results.

*BRANCH* The *Branch* opcode can change program flow based upon an inquiry opcode. The temperature data is interpreted as a program step if the inquiry is true and the atmosphere data as a program step if the inquiry is false. The *DELAY* opcode is used when a short delay is needed. The option value is the delay time in seconds.

*DEV\_AL* This deviation alarm opcode is used to turn the temperature or atmosphere deviation alarms ON or OFF.

The option values are:

- OFF, turns off both the temperature and atmosphere alarms;
- TEMPERATURE, turns on the temperature alarm and turns off the atmosphere alarm;
- ATMOSPHERE, turns on the atmosphere alarm and turns off the temperature alarm; and
- BOTH, turns on both the temperature and the atmosphere alarms.
- The band limit can be changed by the *SET\_WAIT* opcode.

*DOW\_INQ* This opcode checks the real time clock for the day of the week. This is useful for performing operations on a weekly basis on a specific day. The option data is the day of the week, i.e. SUN, MON, TUE, WED, THU, FRI, and SAT.

*EVT\_IN* This opcode waits for an input event to be turned ON or OFF depending on the option value. The option value is the event number followed by either ON or OFF.

If temperature data and/or atmosphere data are specified, they are considered set points and will be sent to the appropriate controller.

*EVT\_OUT* The event output opcode turns ON or OFF an output event based upon the option value. The option value is the event number followed by either ON or OFF.

If temperature data and or atmosphere data are specified, they are considered set points and will be sent to the appropriate controller.

*G\_Ramp* This is a guaranteed ramp opcode. The temperature and or atmosphere process value must be within the deviation band to allow the ramp timer to run. The option values are the ramp time in hours and minutes, temperature and/or atmosphere set point. The band limit can be changed by the *SET\_WAIT* opcode.

*G\_SOAK* This is a guaranteed soak opcode. The temperature process value must be within the deviation band to allow the soak timer to run. The option value is the soak time in hours and minutes. The band limit can be changed by the *SET\_WAIT* opcode.

*G\_SOAK High* This is a guaranteed soak high opcode. The temperature process value must be below the deviation band to allow the soak timer to run. The option value is the soak time in hours and minutes. The band limit can be changed by the *SET\_WAIT* opcode.

*G\_SOAK Low* This is a guaranteed soak low opcode. The temperature process value must be below the deviation band to allow the soak timer to run. The option value is the soak time in hours and minutes. The band limit can be changed by the *SET\_WAIT* opcode.

*GOSUB* The go to subroutine opcode is used to call a program and then return to the calling program. This is used to execute standard routines that can be used by many programs. *GOSUBs* can be stacked up to eight levels. The option data is the program number.

*HIGH\_AL* This opcode is used to enable a high limit alarm on the temperature process and/or the atmosphere process. The temperature data is the high limit point for the temperature process. The atmosphere data is the high limit point for the atmosphere process. This alarm remains active until the program ends.

*HIGH\_PO* This opcode is used to enable a high limit alarm on the temperature percent output and/or the atmosphere percent output. The temperature data is the high limit point for the temperature

percent output. The atmosphere data is the high limit point for the atmosphere percent output. This alarm remains active until the program ends.

*ID\_SET* This opcode is used to set the ID number to the value specified in the temperature data. The atmosphere and option data are not used. The ID number is provided as a feature to track loads or jobs and is not used by any controller.

*ID\_INC* This opcode increments the ID number by one. No data is required.

*ID\_INQUIRY* This opcode is used to compare the ID value to the value in the temperature data. The option data is equal, high, or low. The *LIMIT* opcode immediately following this opcode sets a time limit on the wait. A *BRANCH* opcode immediately following this opcode can be used to change the program flow based on the inquiry results.

*JUMP* The *JUMP* opcode is used to go to another program when no return is needed. The option data is the program number to execute next.

*LIMIT* This option is used to place a time limit on a wait or inquiry step. The option data is the time limit to wait in hours and minutes. Should the time run out before the wait or inquiry is satisfied an alarm occurs.

*LOW\_AL* This opcode is used to enable a low limit alarm on the temperature process and/or the atmosphere process. The temperature data is the low limit point for the temperature process. The atmosphere data is the low limit point for the atmosphere process. This alarm remains active until the program ends.

*LOW\_PO* This opcode is used to enable a low limit alarm on the temperature percent output and/or the atmosphere percent output. The temperature data is the low limit point for the temperature percent output. The atmosphere data is the low limit point for the atmosphere percent output. This alarm remains active until the program ends.

*MV\_INQ* The millivolt inquiry is used to wait for the probe millivolts to reach the value specified in the atmosphere data.

The options are:

- wait, reach within band;
- wait up, reach or exceed the value;
- or wait down, reach or be less than the value.

The *LIMIT* opcode immediately following this opcode sets a time limit on the wait.

A *BRANCH* opcode immediately following this opcode can be used to change the program flow based on the inquiry results.

*PID Select* This is a PID Select opcode. The PIDs stored at PID Select Screen can be implemented for furnace control. The option values are Loop 1, Loop 2 and Loop 3 PID's.

*PO\_INQ* The percent output inquiry is used to test the actual percent output of the temperature and/or atmosphere controller.

The options are:

- wait, reach within band;
- wait up, reach or exceed the specified value;
- or wait down, reach or be less than the specified value.

The *LIMIT* opcode immediately following this opcode sets a time limit on the wait.  
A *BRANCH* opcode immediately following this opcode can be used to change the program flow based on the inquiry results.

*QUENCH* opcode is used to start a quench cycle. The quench cycle is independent of any program that is running. The temperature data is the quench temperature controller set point. The atmosphere data is the quench time in minutes. The option data can be used to control the agitator speed, high or low, by Event # 6. Event # 6 OFF equals low speed, and Event # 6 ON equals high speed. The quench temperature controller must be *Aux Instrument # 4*. The quench cycle starts when the opcode is executed. The set point is sent to the quench temperature controller, the timer is started, and the high-speed event is turned on if it is selected. When the quench timer times out, the end of quench cycle (event # 7) is turned on for one second and the high speed event is turned off.

*RAMP* This opcode changes the temperature set point and/or the atmosphere set point linearly over time. The option data is the total ramp time in minutes. The temperature data specifies the final set point for the temperature set point. The atmosphere data specifies the final value for the atmosphere set point.

*RAMPR* This opcode changes the temperature set point at a rate of degrees per minute. The option data is the final temperature set point and rate of degrees per minute.

*RESET* This opcode is used to clear all stacks and timers and start a program. The temperature data is interpreted as a program number and the atmosphere data as a program step. The option data is not used. The RESET is useful in a weekend shut down program to restart the normal operating program.

*SET\_AUX* The Set Auxiliary Instrument Set point opcode is used with other instruments in the process such as flow control or belt speed. The temperature data is the set point and the option data is the instrument number.

*SET\_FACT* This opcode is used to set the CO factor or the H2 factor of the atmosphere controller. If the atmosphere type for the loop is set to dew point then the H2 factor is set; otherwise the CO factor is set. The temperature data is not used. The atmosphere data is used as the factor with decimal places ignored. The option data is wait, wait up, or wait down. This allows the control loop to recover from the change before continuing the program.

*SET\_WAIT* This opcode sets the band limits for the wait option or inquiry opcodes. The temperature data specifies the temperature band (i.e. +/- the value) and the atmosphere data specifies the atmosphere band.

*SETPT* This opcode is used to set the temperature and/or atmosphere set points. Either or both of the set points can be specified. The options are None or Wait. If both set points are specified the Wait applies to both.

*SOAK* This opcode is an unconditional soak for the time (in hours and minutes) specified in the option data.

*TC\_INQ* The temperature inquiry is used to wait for the actual control temperature to reach the value specified in the "temp" field.

The options are:

- wait, reach within band;
- wait up, reach or exceed the set point;

- or wait down, reach or be less than the set point.

The default band can be set under the Configuration Menu and is typically 15 degrees. The band limit can be changed by the *SET\_WAIT* opcode.

The *LIMIT* opcode immediately following this opcode sets a time limit on the wait. A *BRANCH* opcode immediately following this opcode can be used to change the program flow based on the inquiry results.

*TOD\_INQ* This opcode is a time of day inquiry that would be used to start a process or subroutine at a specific hour and minute. The option data is the time in 24-hour format (i.e. 2:30pm is 14:30).

*ZONE\_OFF* The Zone Offset opcode is used to set an offset to be added to the set point sent to a specific zone. Either temperature, atmosphere, or both can be offset. The same loop (furnace) can have different offsets for each zone. The zones must be defined in the zone configuration.

For example, a pit furnace has three zones: top, middle, and bottom.

The zones could be defined as:

- top = zone 1,
- middle = zone 2 ,
- bottom = zone 3.

If the *ZONE\_OFF* opcode is used in a program with temperature data = 50 and zone = 1, then a temperature set point value in the following steps of 1700 would be sent to the middle and bottom as 1700 and the top as 1750.

## Chapter 5 - APPLICATIONS INFORMATION

---

### 9200 MMI Protocol Register Mapping

July 16, 2004

The 9200 maps the most common parameters to be as compatible as possible to a MMI FDP VER. 3.X commonly referred as a Dualpro. (Dualpro). Reads of table 0 blocks 0, 1, 6, 7, and 8 are mapped. Table 31 block 0 is mapped for probe maintenance data only. Data is mapped into the Dualpro format only if there is a reasonable correlation between the 9200 parameters and the Dualpro parameters. Other values in these blocks are returned as 0.

The 9200 will return an error message instead of data under the following conditions:

Table number greater than 12, except table 31 block 0.

Block number greater than 9.

Block number greater than 3 except for table 0.

Reads of blocks not mapped or returning an error read the equivalent Modbus registers. For table zero the 24 words (registers) start at the block number times 24. Therefore, block 2 would start at Modbus register 48, block 3 at 72, etc. For tables 1 through 12 the start register of the block is equal to 900 plus the table number times 100 plus block number times 24. Tables 1 through 12 access the slave instrument data on the 9200.

The parameter write command (X) is mapped for seven parameters.

PF1 is mapped to CO factor.

PF2 is mapped to H2 factor.

Ref Num is mapped to ID num.

Set point 1 is mapped to Loop 1 set point.

Set point 2 is mapped to Loop 2 set point.

Alarm 1 set point is mapped to Alarm 1 set point.

Alarm 2 set point is mapped to Alarm 2 set point.

The Program control command (P) should be able to start and stop SSi recipes.

### Default Values

Series 9200 Factory defaults

August 17, 2003.

Rev August 6, 2004

### Values independent of PV type

Parameter	Default	Factory Setting	Customer Setting
RS-232 Host baud	19200		
RS-232 Host Mode	Modbus		
RS-485 Host baud	19200		
RS-485 Host Mode	Modbus		
RS-485 Slave 1 baud	19200		
RS-485 Slave 1 Mode	Modbus		
RS-485 Slave 2 baud	19200		
RS-485 Slave 2 Mode	Modbus		

## Model 9200 Programmable Dual-loop Controller

Pass code 1	1		
Pass code 2	2		
Web code 1	111		
Web code 2	222		
Web change enable	yes		
PV 1 Name	Temperature 1		
PV 2 Name	Temperature 2		
PV 3 Name	Temperature 3		
AD 1 filter time	0		
AD 2 filter time	0		
AD 3 filter time	0		
AD 4 filter time	0		
IN 1 initial scale	0		
IN 1 Full scale	1000		
IN 2 initial scale	0		
IN 2 Full scale	10000		
IN 3 initial scale	0		
IN 3 Full scale	10000		
IN 4 initial scale	0		
IN 4 Full scale	10000		
IN 1 Decimal place	0		
IN 2 Decimal place	0		
IN 3 Decimal place	0		
IN 4 Decimal place	0		
Burn off time	90 secs		

### Values independent of PV type

Parameter	Default	Factory Setting	Customer Setting
Burn off recovery wait	120 secs		
Burn off Interval	720 minutes		
Burn off min MV	800		
Burn off max temperature	2000		
CO factor	200		
H factor	400		
Event hold	none		
Event hold polarity	all N.O.		
Hold instrument	none		
Hold PV min	0		
Hold PV max	2000		
Event run	None (-1)		
Event reset	None (-1)		
Slave Instrument setups	None		
Zone Assignments	None		
SPP ATM instrument	Internal loop 1		
SPP Temperature Inst	Internal loop 2		
SPP Event instrument	Internal		

## Model 9200 Programmable Dual-loop Controller

Quench instrument	Loop 3		
Quench events			
Temperature default wait limit	15		
Atmosphere default wait limit	10		
IP address	192.168.0.200		
IP net mask	255.255.255.0		
IP gateway	192.168.1.1		
Temperature mode	Fahrenheit		
Loop 1 setpoint	0		
Loop 1 prop band	20		
Loop 1 reset	0.1		
Loop 1 rate	0		
Loop 1 cycle time	16		
Loop 1 auto/manual	auto		
Loop 1 integral preset	0		
Loop 2 setpoint	0		
Loop 2 prop band	4		
Loop 2 reset	0.1		
Loop 2 rate	0		
Loop 2 cycle time	60		
Loop 2 auto/manual	auto		
Loop 2 integral preset	0		

### Values independent of PV type

Parameter	Default	Factory Setting	Customer Setting
Loop 3 setpoint	0		
Loop 3 prop band	4		
Loop 3 reset	0.1		
Loop 3 rate	0		
Loop 3 cycle time	16		
Loop 3 auto/manual	auto		
Loop 3 integral preset	0		
IR RH cutoff	101%		
IR CO span gas	20%		
IR CO2 span gas	1.00%		
IR CH4 span gas	5.00%		
IR mode	monitor		
IR min temperature	1400		
IR min MV	1000		
IR ON delay	10 sec		
IR OFF delay	10 sec		
IR max adjust	10		
IR max factor	300		
IR min factor	100		
IR update time	5 min		



## **Model 9200 Programmable Dual-loop Controller**

IR MV action	turns off sample only		
IR temperature source	probe temperature		
IR shim factor	150		
IR CH4 factor	65		
IR CO adjust factor	200		

### Sample Recipe - % Carbon and Temperature (Batch Furnace)

#### Standard Event Assignments

To simplify operation and maintain consistency, SSI has adopted the following event assignments.

Event 0	Program Alarm
Event 1	End of Cycle
Event 2	Ammonia
Event 3	Plunge Cool
Event 6	Quench Speed
Event 7	End of Quench

Events 0, 6, and 7 are fixed assignments in the SERIES 9200.

<u>Step No</u>	<u>OPT CODE</u>	<u>TEMP</u>	<u>ATM</u>	<u>OPTIONS</u>
<u>S1</u>	<u>SET PT</u>	<u>1700</u>		<u>WAIT</u>
<u>S2</u>	<u>SET PT</u>	<u>1700</u>	<u>.85</u>	<u>WAIT</u>
<u>S3</u>	<u>SOAK</u>			<u>4.0</u>
<u>S4</u>	<u>EVT-OUT</u>			<u>3 - ON</u>
<u>S5</u>	<u>TC-INQ</u>	<u>1565</u>		<u>WAIT DOWN</u>
<u>S6</u>	<u>DELAY</u>			<u>5</u>
<u>S7</u>	<u>EVT-OUT</u>			<u>3 - OFF</u>
<u>S8</u>	<u>SET PT</u>	<u>1550</u>	<u>.70</u>	<u>WAIT</u>
<u>S9</u>	<u>SOAK</u>			<u>1.0</u>
<u>S10</u>	<u>EVT-OUT</u>			<u>1 - ON</u>
<u>S11</u>	<u>ALARM</u>			<u>1</u>
<u>S12</u>	<u>EVT-OUT</u>			<u>1 - OFF</u>

#### Flash Card Management

This section will show the user how to pull logged data from an Advantech screen and view it on the PC using a flash card reader and SD Recorder. This option requires SDRRecorder to be installed on the local computer. If SDRRecorder is not installed, see the section *SDRecorder Installation* for instructions on how to install the SDRRecorder software. If SDRRecorder is installed, continue on with these instructions.

1. Shut down the screen software. To shut down the screen software, press the **Menu** button from the Default Display Screen. This will display the *Configuration* menu list. Select the *Shutdown* menu option and confirm the shutdown process. See the section *Shutdown* in the *Chapter 2 - Configuration* section of this manual for more information on shutting down the screen software.
2. When the Windows desktop is visible, turn off the screen using the power switch located on the back of the screen just above the power connector.
3. Remove the compact flash card from the top rear of the screen. *Note - Be sure to remember the orientation of the compact flash card with respect to the screen. The compact flash card will only fit into the screen one way.*
4. Read the flash card with a compact flash card reader onto a PC. Copy the contents of the "\SSI\COMP\ folder and the \SSI\LOG\ folder into a folder on the PC. *Note - The location of this*

folder can be anywhere on the PC, however, it is recommended that the user keep the location of this folder simple – i.e. directly on the main drive (C:\). For example, the location “C:\9200 Data\” is better than “C:\SSi\Devices\9200\Data\”.

5. It is also helpful to include the INTPARMS.x files, chlst.txt file, and any associated chart files (.CTM) into the selected folder. These files should be located on the installation CD.
6. Open SD Recorder.
7. From the *Options* menu on SD Recorder, select *Alternate Data*. The user will have to enter the location of the alternate data, which is the location of the selected folder, i.e. “C:\9200 Data”.

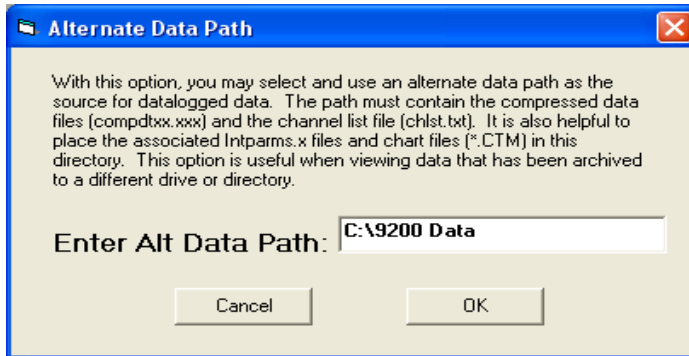

Click the **OK** button to use the alternate data that was pulled off of the compact flash card.

SDRecorder Installation

The SDRecorder Installation installs the SDRecorder program and associated files onto the PC. SDRecorder is used to allow the user to view and print data logged data in a chart or tabular format. To install the program follow the steps listed below:

1. From the Installation CD double-click on the SD\_SDRecetup.exe file. The following screen will appear:



2. Click on the Next button.

The following screen will appear:

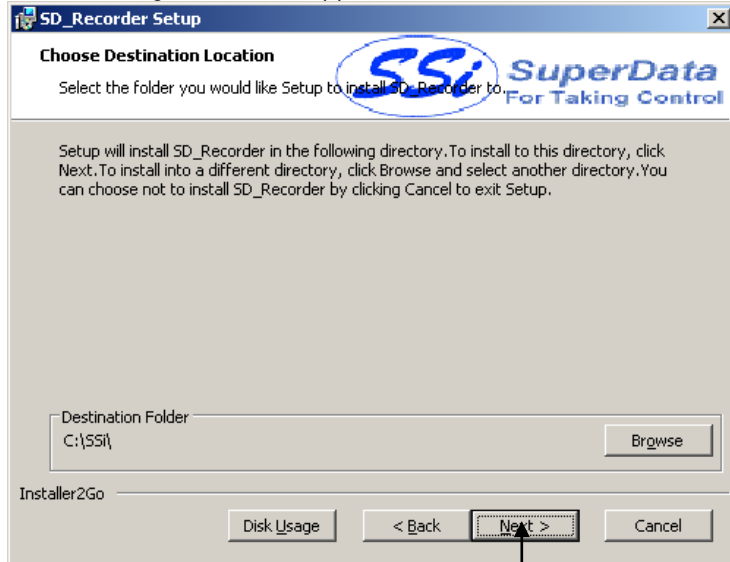

3. Click on the Next button.

The following screen will appear:

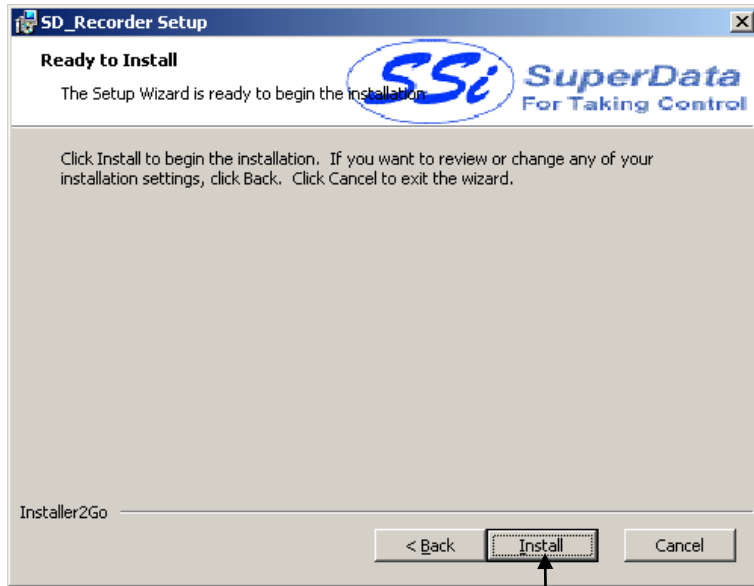

4. Click on the Install button.

5. Once the Program has finished being installed the following screen will appear. Click on the Finish button.



## **Model 9200 Programmable Dual-loop Controller**

### Slave Instrument Mapping

The following tables can be used as a reference for retrieving information such as the PV, setpoint, etc from a slave instrument. The slave instrument information will have a base offset based on the instrument number that is assigned. The base offset can be determined using the following formula:

$$\text{Base Offset} = (\text{Instrument Number} * 100) + 900$$

For example, the base offset for instrument 1 would be 1000 → (1 \* 100) + 900 – and the base offset for instrument 7 would be 1600 → (7 \* 100) + 900. The slave instruments will be split into three sections: Atmosphere Instruments, Temperature Instruments, and Events Instruments. The layout for each instrument will be the same:

- Controller – The type of controller the slave instrument is – i.e. AC20, Series 9200, etc.
- Source Location – The register *in the controller* where the specified value is located. *Note: These will be added on to the base offset of the instrument (see above section).* For example, the source location for %C actual for an AC20 is 11. For instrument 1, the register to find the %C actual would be 1011 → the base offset for instrument 1 is 1000, plus the source location of 11.
- Write Register – The register *within the slave instrument* where the value will be written.
- Read Scale – Any value read in from an instrument will be divided by this number for display purposes only.
- Write Scale – Any value written to an instrument will be multiplied by this number for display purposes only.
- Description – This will be a brief description of what the value is, i.e. %C actual, Setpoint, etc.

### Atmosphere Instruments

Controller	Source Location	Write Register	Read Scale	Write Scale	Description
AC20	11	123	1	1	%C Actual
(Modbus Mode)	29	138	1	1	%C Setpoint
	13	125	1	1	Probe Temperature
	10	122	1	1	Probe Millivolts
	20	130	10	10	%C Percent Output
	34	142	1	1	CO Factor or Equivalent
	35	143	1	1	H Factor or Equivalent
	12	124	1	1	Dew Point
	36	144	10	10	O2

Controller	Source Location	Write Register	Read Scale	Write Scale	Description
Yoko 750	2	2	1	1	%C Actual
(Modbus Mode)	3	100	1	1	%C Setpoint
	20	19	1	1	Probe Temperature
	10	122	1	1	Probe Millivolts
	4	4	10	10	%C Percent Output
	0	0	1	1	CO Factor or Equivalent
	0	0	1	1	H Factor or Equivalent

**Model 9200 Programmable Dual-loop Controller**

Controller	Source Location	Write Register	Read Scale	Write Scale	Description
UDC 3300's	1	0	1	1	%C Actual
(Modbus Mode)	3	2	1	1	%C Setpoint
	6	5	10	10	Probe Temperature
	5	4	10	10	Probe Millivolts
	4	3	10	10	%C Percent Output
	43	39	10	10	CO Factor or Equivalent
	43	39	10	10	H Factor or Equivalent

Controller	Source Location	Write Register	Read Scale	Write Scale	Description
Dualpro Loop 1	21	20	1	1	%C Actual
(Modbus Mode)	7	6	1	1	%C Setpoint
	18	17	8	8	Probe Temperature
	19	18	8	8	Probe Millivolts
	41	40	41	41	%C Percent Output
	4	3	1	1	CO Factor or Equivalent
	5	4	1	1	H Factor or Equivalent

Controller	Source Location	Write Register	Read Scale	Write Scale	Description
Dualpro Loop 2	21	20	1	1	%C Actual
(Modbus Mode)	8	7	1	1	%C Setpoint
	18	17	8	8	Probe Temperature
	19	18	8	8	Probe Millivolts
	42	41	41	41	%C Percent Output
	4	3	1	1	CO Factor or Equivalent
	5	4	1	1	H Factor or Equivalent

Controller	Source Location	Write Register	Read Scale	Write Scale	Description
Dualpro Loop 1	20	20	1	1	%C Actual
(MMI Mode)	6	6	1	1	%C Setpoint
	17	17	8	8	Probe Temperature
	18	18	8	8	Probe Millivolts
	40	40	41	41	%C Percent Output
	3	3	1	1	CO Factor or Equivalent
	4	4	1	1	H Factor or Equivalent

Controller	Source Location	Write Register	Read Scale	Write Scale	Description
Dualpro Loop 2	20	20	1	1	%C Actual
(MMI Mode)	7	7	1	1	%C Setpoint
	17	17	8	8	Probe Temperature
	18	18	8	8	Probe Millivolts
	41	41	41	41	%C Percent Output
	3	3	1	1	CO Factor or Equivalent
	4	4	1	1	H Factor or Equivalent

Controller	Source	Write	Read	Write Scale	Description
------------	--------	-------	------	-------------	-------------

### Model 9200 Programmable Dual-loop Controller

	Location	Register	Scale		
Eurotherm 2404	1	1	1	1	%C Actual
(Modbus Mode)	5	5	1	1	%C Setpoint
	72	11073	1	1	Probe Temperature
	61	11062	1	1	Probe Millivolts
	4	4	1	1	%C Percent Output
	0	0	1	1	CO Factor or Equivalent
	0	0	1	1	H Factor or Equivalent

Controller	Source Location	Write Register	Read Scale	Write Scale	Description
Eurotherm 2500	1	1	1	1	%C Actual
(Modbus Mode)	5	5	1	1	%C Setpoint
	72	11073	1	1	Probe Temperature
<i>Assumes Loop 1 = Atmosphere</i>	61	11062	1	1	Probe Millivolts
	4	4	1	1	%C Percent Output
	68	11069	1	1	CO Factor or Equivalent
	68	11069	1	1	H Factor or Equivalent

Controller	Source Location	Write Register	Read Scale	Write Scale	Description
Carbpro 3.5	6	28	1	1	%C Actual
(MMI Mode)	1	1	1	1	%C Setpoint
	5	25	8	8	Probe Temperature
	4	24	8	8	Probe Millivolts
	11	117	1	1	%C Percent Output
	13	7	1	1	CO Factor or Equivalent
	14	8	1	1	H Factor or Equivalent

Controller	Source Location	Write Register	Read Scale	Write Scale	Description
Carbpro 3.0	6	28	4	4	%C Actual
(MMI Mode)	1	1	1	1	%C Setpoint
	5	25	8	8	Probe Temperature
	4	24	2	2	Probe Millivolts
	11	117	1	1	%C Percent Output
	13	7	1	1	CO Factor or Equivalent
	14	8	1	1	H Factor or Equivalent

Controller	Source Location	Write Register	Read Scale	Write Scale	Description
Carbpc	20	20	1	1	%C Actual
(MMI Mode)	6	6	1	1	%C Setpoint
	17	17	8	8	Probe Temperature
	18	18	8	8	Probe Millivolts
	64	64	41	41	%C Percent Output
	3	3	1	1	CO Factor or Equivalent
	4	4	1	1	H Factor or Equivalent

Controller	Source Location	Write Register	Read Scale	Write Scale	Description
------------	-----------------	----------------	------------	-------------	-------------

**Model 9200 Programmable Dual-loop Controller**

Series 9200 Loop 1	3	126	1	1	%C Actual
	5	128	1	1	%C Setpoint
	22	145	1	1	Probe Temperature
	21	144	10	10	Probe Millivolts
	7	130	10	10	%C Percent Output
	19	142	1	1	CO Factor or Equivalent
	20	143	1	1	H Factor or Equivalent

Temperature Instruments

Controller	Source Location	Write Register	Read Scale	Write Scale	Description
Series 20	11	123	1	1	Temperature Controller Actual
(Modbus Mode)	30	138	1	1	Temperature Controller Setpoint
	18	130	10	10	Temperature Controller Percent Output

Controller	Source Location	Write Register	Read Scale	Write Scale	Description
Yoko 750	2	2	1	1	Temperature Controller Actual
(Modbus Mode)	3	100	1	1	Temperature Controller Setpoint
	4	4	10	10	Temperature Controller Percent Output

Controller	Source Location	Write Register	Read Scale	Write Scale	Description
UDC 3300's	1	0	10	10	Temperature Controller Actual
(Modbus Mode)	3	2	10	10	Temperature Controller Setpoint
	4	3	10	10	Temperature Controller Percent Output

Controller	Source Location	Write Register	Read Scale	Write Scale	Description
Dualpro Loop 1	18	17	8	8	Temperature Controller Actual
(Modbus Mode)	7	6	1	1	Temperature Controller Setpoint
	41	40	41	41	Temperature Controller Percent Output

Controller	Source Location	Write Register	Read Scale	Write Scale	Description
Dualpro Loop 2	18	17	8	8	Temperature Controller Actual
(Modbus Mode)	8	7	1	1	Temperature Controller Setpoint
	42	41	41	41	Temperature Controller Percent Output

Controller	Source Location	Write Register	Read Scale	Write Scale	Description
Dualpro Loop 1	17	17	8	8	Temperature Controller Actual
(MMI Mode)	6	6	1	1	Temperature Controller Setpoint
	40	40	41	41	Temperature Controller Percent Output



## Model 9200 Programmable Dual-loop Controller

Controller	Source Location	Write Register	Read Scale	Write Scale	Description
Dualpro Loop 2	17	17	8	8	Temperature Controller Actual
(MMI Mode)	7	7	1	1	Temperature Controller Setpoint
	41	41	41	41	Temperature Controller Percent Output

Controller	Source Location	Write Register	Read Scale	Write Scale	Description
Eurotherm 2404	1	1	1	1	Temperature Controller Actual
(Modbus Mode)	2	2	1	1	Temperature Controller Setpoint
	3	3	10	10	Temperature Controller Percent Output

Controller	Source Location	Write Register	Read Scale	Write Scale	Description
Eurotherm 2500	26	1025	1	1	Temperature Controller Actual
(Modbus Mode)	27	1026	1	1	Temperature Controller Setpoint
<i>Assumes Loop 2 is Temperature</i>	29	1028	10	10	Temperature Controller Percent Output

Controller	Source Location	Write Register	Read Scale	Write Scale	Description
Unipro 3.5	3	25	8	8	Temperature Controller Actual
(MMI Mode)	1	1	1	1	Temperature Controller Setpoint
	5	118	1	1	Temperature Controller Percent Output

Controller	Source Location	Write Register	Read Scale	Write Scale	Description
Unipro 3.0	3	25	8	8	Temperature Controller Actual
(MMI Mode)	1	1	1	1	Temperature Controller Setpoint
	5	118	1	1	Temperature Controller Percent Output

Controller	Source Location	Write Register	Read Scale	Write Scale	Description
Carbpro 3.5 Slave	9	46	1	1	Temperature Controller Actual
(MMI Mode)	3	18	1	1	Temperature Controller Setpoint
	12	53	41	41	Temperature Controller Percent Output

Controller	Source Location	Write Register	Read Scale	Write Scale	Description
Carbpro 3.0 Slave	9	46	1	1	Temperature Controller Actual
(MMI Mode)	3	18	1	1	Temperature Controller Setpoint
	12	53	41	41	Temperature Controller Percent Output

Controller	Source	Write	Read	Write	Description
------------	--------	-------	------	-------	-------------

**Model 9200 Programmable Dual-loop Controller**

	Location	Register	Scale	Scale	
10Pro Slave or E Slave	2	2	1	1	Temperature Controller Actual
(MMI Mode)	3	3	1	1	Temperature Controller Setpoint
	4	4	1	1	Temperature Controller Percent Output

Controller	Source Location	Write Register	Read Scale	Write Scale	Description
Dualpro Input C	19	19	8	8	PV
	5	5	1	1	Setpoint Loop 1
	40	40	41	41	Percent Output Loop 1

Controller	Source Location	Write Register	Read Scale	Write Scale	Description
Series 9200 Loop 1	3	126	1	1	Temperature Controller Actual
	5	128	1	1	Temperature Controller Setpoint
	7	130	10	10	Temperature Controller Percent Output

Controller	Source Location	Write Register	Read Scale	Write Scale	Description
Series 9200 Loop 2	8	131	1	1	Temperature Controller Actual
	10	133	1	1	Temperature Controller Setpoint
	12	135	10	10	Temperature Controller Percent Output

Controller	Source Location	Write Register	Read Scale	Write Scale	Description
Series 9200 Loop 3	13	136	1	1	Temperature Controller Actual
	15	138	1	1	Temperature Controller Setpoint
	17	140	10	10	Temperature Controller Percent Output

Controller	Source Location	Write Register	Read Scale	Write Scale	Description
Series 9100 Loop 2	1	104	1	1	Temperature Controller Actual
	36	139	1	1	Temperature Controller Setpoint
	28	131	10	10	Temperature Controller Percent Output

Controller	Source Location	Write Register	Read Scale	Write Scale	Description
Eurotherm Loop 1	1	1	1	1	Temperature Controller Actual
(Modbus Mode)	2	2	1	1	Temperature Controller Setpoint
	3	3	10	10	Temperature Controller Percent Output

Controller	Source Location	Write Register	Read Scale	Write Scale	Description
Eurotherm Loop 2	26	1025	1	1	Temperature Controller Actual
(Modbus Mode)	27	1026	1	1	Temperature Controller Setpoint

### Model 9200 Programmable Dual-loop Controller

	29	1028	10	10	Temperature Controller Percent Output
--	----	------	----	----	---------------------------------------

Controller	Source Location	Write Register	Read Scale	Write Scale	Description
Eurotherm Loop 3	51	1049	1	1	Temperature Controller Actual
(Modbus Mode)	52	1050	1	1	Temperature Controller Setpoint
	53	1052	10	10	Temperature Controller Percent Output

Controller	Source Location	Write Register	Read Scale	Write Scale	Description
9500 Valve Controller Valve 1	30	130	1	1	Flow Actual
	56	156	1	1	Flow Setpoint
	54	154	1	1	Flow Percent of Full Scale

Controller	Source Location	Write Register	Read Scale	Write Scale	Description
9500 Valve Controller Valve 2	31	131	1	1	Flow Actual
	66	166	1	1	Flow Setpoint
	64	164	1	1	Flow Percent of Full Scale

Controller	Source Location	Write Register	Read Scale	Write Scale	Description
9500 Valve Controller Valve 3	32	132	1	1	Flow Actual
	76	176	1	1	Flow Setpoint
	74	174	1	1	Flow Percent of Full Scale

Controller	Source Location	Write Register	Read Scale	Write Scale	Description
9500 Valve Controller Valve 4	33	133	1	1	Flow Actual
	86	186	1	1	Flow Setpoint
	84	184	1	1	Flow Percent of Full Scale

Controller	Source Location	Write Register	Read Scale	Write Scale	Description
SSi 7SL Limit Controller	4	123	1	1	Limit Controller Actual
	8	177	1	1	Limit Controller Alarm Threshold (SP)
	11	310	1	1	Limit Controller Main Setpoint

Controller	Source Location	Write Register	Read Scale	Write Scale	Description
Flow Meter	1	16	1	1	Flow
	3	18	1	1	Setpoint
	0	0	1	1	<i>No Value Available</i>

**Model 9200 Programmable Dual-loop Controller**

Controller	Source Location	Write Register	Read Scale	Write Scale	Description
UMC 800 Loop 1	0	64	1	1	PV Actual
<i>All Values are Floating Point</i>	4	68	1	1	Working Setpoint
	6	70	1	1	Percent Output

Controller	Source Location	Write Register	Read Scale	Write Scale	Description
SSi Quad DAC Ch. 0	10	10	1	1	DAC Out
	10	10	1	1	DAC Out
	16	16	1	1	<i>No Value Available</i>

Controller	Source Location	Write Register	Read Scale	Write Scale	Description
SSi Quad DAC Ch. 1	11	11	1	1	DAC Out
	11	11	1	1	DAC Out
	16	16	1	1	<i>No Value Available</i>

Controller	Source Location	Write Register	Read Scale	Write Scale	Description
SSi Quad DAC Ch. 2	12	12	1	1	DAC Out
	12	12	1	1	DAC Out
	16	16	1	1	<i>No Value Available</i>

Controller	Source Location	Write Register	Read Scale	Write Scale	Description
SSi Quad DAC Ch. 3	13	13	1	1	DAC Out
	13	13	1	1	DAC Out
	16	16	1	1	<i>No Value Available</i>

Controller	Source Location	Write Register	Read Scale	Write Scale	Description
Yoko UT350/320	2	2	1	1	Temperature Controller Actual
(Modbus Mode)	3	300	1	1	Temperature Controller Setpoint
	4	4	10	10	Temperature Controller Percent Output

Controller	Source Location	Write Register	Read Scale	Write Scale	Description
Yoko UP750/550 Loop 2	18	18	1	1	Temperature Controller Actual
(Modbus Mode)	19	101	1	1	Temperature Controller Setpoint
	20	20	10	10	Temperature Controller Percent Output

Controller	Source	Write	Read	Write	Description
------------	--------	-------	------	-------	-------------

## Model 9200 Programmable Dual-loop Controller

	Location	Register	Scale	Scale	
Yoko UP350	2	2	1	1	Temperature Controller Actual
(Modbus Mode)	3	138	1	1	Temperature Controller Setpoint
	4	4	10	10	Temperature Controller Percent Output

Controller	Source Location	Write Register	Read Scale	Write Scale	Description
Honeywell DCP551	4	259	10	10	Temperature Controller Actual
	5	702	10	10	Temperature Controller Setpoint
	0	0	10	10	Temperature Controller Percent Output

### Events Instruments

Controller	Source Location	Write Register	Read Scale	Write Scale	Description
AC20	50	310	1	1	Events Actual
(Modbus Mode)	50	310	1	1	Events Setpoint
	49	300	1	1	Events Input

Controller	Source Location	Write Register	Read Scale	Write Scale	Description
Yoko 750	49	310	1	1	Events Actual
(Modbus Mode)	49	310	1	1	Events Setpoint
	49	310	1	1	Events Input

Controller	Source Location	Write Register	Read Scale	Write Scale	Description
ModMux	97	97	1	1	Events Actual
(Modbus Mode)	97	97	1	1	Events Setpoint
	98	98	1	1	Events Input

Controller	Source Location	Write Register	Read Scale	Write Scale	Description
Dualpro Events	59	178	1	1	Events Actual
(Modbus Mode)	49	168	1	1	Events Setpoint
	59	178	1	1	Events Input

Controller	Source Location	Write Register	Read Scale	Write Scale	Description
Dualpro Events	82	178	1	1	Events Actual
(MMI Mode)	72	168	1	1	Events Setpoint
	82	178	1	1	Events Input

Controller	Source Location	Write Register	Read Scale	Write Scale	Description
Carbpro 3.5 Events	8	43	1	1	Events Actual
(MMI Mode)	2	17	1	1	Events Setpoint
	8	43	1	1	Events Input

**Model 9200 Programmable Dual-loop Controller**

Controller	Source Location	Write Register	Read Scale	Write Scale	Description
Carbpro 3.0 Events	8	43	1	1	Events Actual
(MMI Mode)	2	17	1	1	Events Setpoint
	8	43	1	1	Events Input

Controller	Source Location	Write Register	Read Scale	Write Scale	Description
Eurotherm 2500	19	19	8	8	PV
(Modbus Mode)	5	5	1	1	Setpoint Loop 1
	40	40	1	1	Percent Output Loop 1

Controller	Source Location	Write Register	Read Scale	Write Scale	Description
SSi_8_8	5	100	1	1	Events Actual
	3	98	1	1	Events Setpoint
	6	101	1	1	Events Input

Controller	Source Location	Write Register	Read Scale	Write Scale	Description
Series 9200	5	176	1	1	Events Actual
	2	109	1	1	Events Setpoint
	4	175	1	1	Events Input

Controller	Source Location	Write Register	Read Scale	Write Scale	Description
Micrologix Modbus	10	110	1	1	Events Actual
RS-232	0	100	1	1	Events Setpoint
	15	115	1	1	Events Input

Controller	Source Location	Write Register	Read Scale	Write Scale	Description
MCMModule Modbus	10	110	1	1	Events Actual
RS-232	0	100	1	1	Events Setpoint
	15	115	1	1	Events Input

Controller	Source Location	Write Register	Read Scale	Write Scale	Description
PLC5DF1	10	110	1	1	Events Actual
RS-232	0	100	1	1	Events Setpoint
	15	115	1	1	Events Input

Controller	Source Location	Write Register	Read Scale	Write Scale	Description
SLKDF1	10	110	1	1	Events Actual
RS-232	0	100	1	1	Events Setpoint
	15	115	1	1	Events Input



## Revision History

Rev.	Description	Date	MCO #
-	Initial Release	04-24-2001	N/A
A	Added Revision History	07-11-2001	N/A
B	Added	09-03-2004	N/A
C	Added "Opcode" description enhancement, TC_INQ & ATM_INQ Added "Change Setpoint" definition to PID Loops	01-17-2005	2034
D	Added several operator functions from a Field Technicians perspective	03-25-2005	2035
E	SSi address & general update	05-17-2005	N/A
F	Added Tuning Assistant menu option; Added "Flash Card Management" option; Added "Slave Instrument Mapping" section; Updated "Revision History" section; Updated title page; Updated "Analog Output Setup" section; Updated menus; Added "ADAM Correction" menu; Added "Aux SP Configuration" menu; Added "SDRecorder Installation" section; Modified picture layouts	11-1-2007	2045
G	Changed default IP Address to "192.168.0.200"	01-07-2008	2059
H	Added reference to TS Manager manual for changing IP address, mask, and gateway of touchscreen.	5-26-2017	2215
I	Corrected description of G_SOAK High opcode	8-18-2017	2222
J	Added operating range	7/28/2018	2235
K	Added TS mounting instructions	12/3/2018	2245