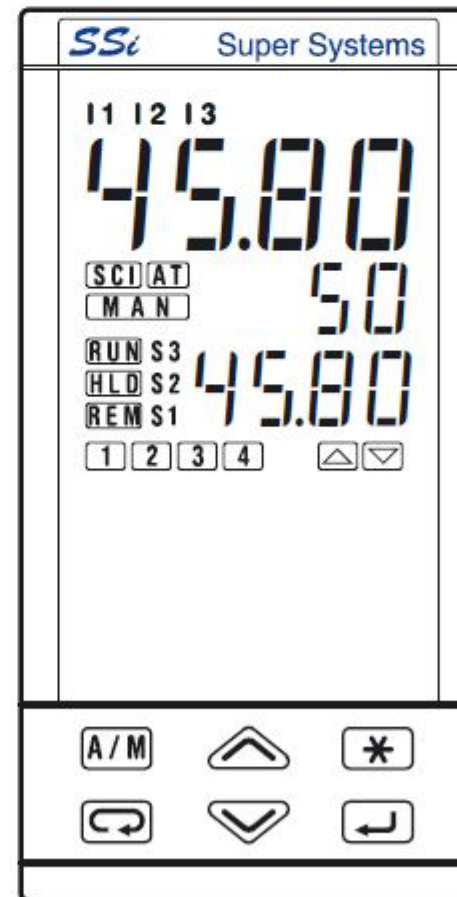

Model No. 31095 and 31097

Instruction manual
PN 31095
PN 31097

Super System inc.
7205 Edington Drive
Cincinnati, Ohio 45249
United States

Phone: 513-772-0060

Fax: 513-772-9466
www.supersystems.com





NOTES

ON ELECTRIC SAFETY AND ELECTROMAGNETIC COMPATIBILITY

Please read these instructions carefully before proceeding with the installation of the controller.

Class II instrument (for indoor use only).

This controller has been designed in compliance with:

Regulations on electrical apparatus (appliance, systems and installations) according to the European Community directive no. 73/23/EEC amended by the European Community directive no. 93/68/EEC and the Regulations on the essential protection requirements in electrical apparatus EN61010-1 : 93 + A2:95.

Regulations on Electromagnetic Compatibility according to the European Community directive no. 89/336/EEC, amended by the European Community directive no. 92/31/EEC, 93/68/EEC, 98/13/EEC and the following regulations:

Regulations on RF emissions

EN61000-6-3 : 2001 residential environments

EN61000-6-4 : 2001 industrial environments

Regulation on RF immunity

EN61000-6-2 : 2001 industrial equipment and system

It is the responsibility of the installer to ensure compliance with regulations on safety requirements and EMC.

The device has no user serviceable parts. Please contact your nearest agent for repair services.

All information and warnings about safety and electromagnetic compatibility are marked with the  CE symbol.

TABLE OF CONTENTS

1	INTRODUCTION	page 4	5	DISPLAYS	page 57
	1.1 PRODUCT CODING.....	page 5		5.1 STANDARD DISPLAY.....	page 57
2	INSTALLATION	page 6		5.2 FAST ACCESS.....	page 57
	2.1 DESCRIPTION.....	page 6	6	COMMANDS	page 58
	2.2 ENVIRONMENTAL RATINGS.....	page 8		6.1 KEYPAD COMMANDS.....	page 59
	2.3 PANEL MOUNTING.....	page 9		6.2 DIGITAL INPUTS COMMANDS.....	page 58
3	ELECTRICAL CONNECTIONS	page 10		6.3 COMMANDS FROM SERIAL COMMUNICATION (PLEASE, REFER TO THE SERIAL COMMUNICATIONS MANUAL)	
	3.1 TERMINATION BLOCK.....	page 10	7	TECHNICAL SPECIFICATIONS	page 63
	3.2 SUGGESTED WIRES ROUTING.....	page 11			
	3.3 EXAMPLE OF WIRING DIAGRAM.....	page 12			
4	OPERATIONS	page 22			
	4.1 KEYS FUNCTIONS AND DISPLAY IN OPERATOR MODE.....	page 22			
	4.2 PARAMETER SETTING.....	page 24			
	4.3 CONFIGURATION PROCEDURE.....	page 25			
	4.4 PARAMETERISATION - MAIN MENU.....	page 34			
	4.5 PARAMETERS.....	page 46			
	4.6 PARAMETERISATION - ACCESS LEVELS.....	page 50			

1 INTRODUCTION

The 31095 has been designed for use in industrial environments. The 31095 is a universal controller with many standard features.

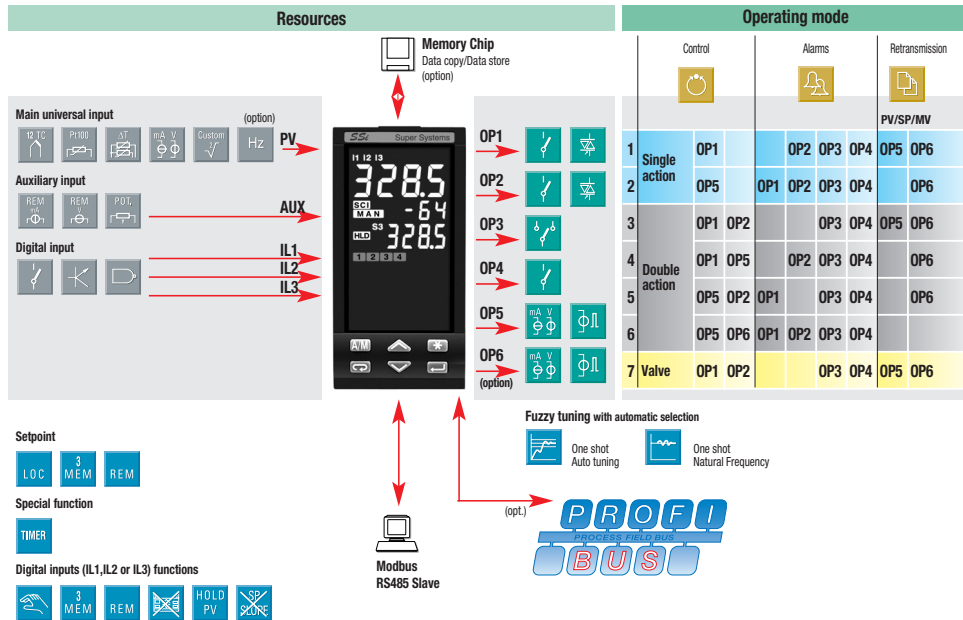

1.1 MODEL CODE

The complete code is displayed on the instrument side label.

The information about product coding is accessible from the front panel by means of a particular procedure described in section 5.1 page 53.

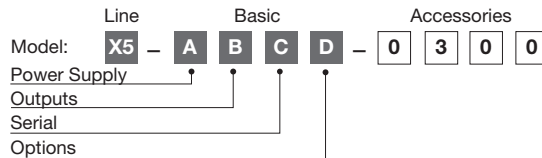
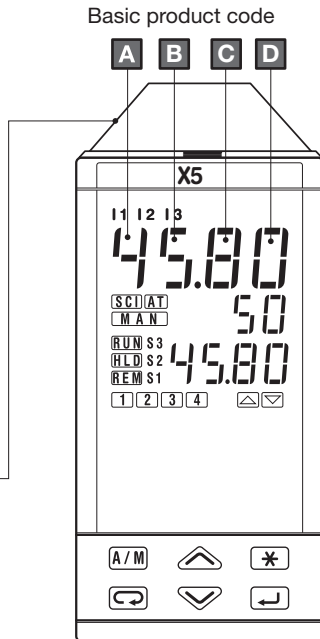
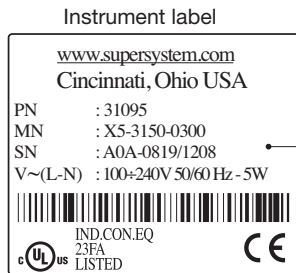

Power supply	A
100...240Vac (- 15% + 10%)	3
24Vac (-25...+12%) or 24Vdc (-15... +25%)	5

Outputs OP1 - OP2	B
Relay - Relay	1
Triac - Triac	5



Serial Communications	C
None	0
RS485 Modbus/Jbus SLAVE	5
PROFIBUS DP SLAVE	7
RS485 Modbus/Jbus SLAVE + PROFIBUS	8

Options	D
None	0
2 nd SSR drive/analog output (OP6)	4



INSTALLATION

Installation must be carried out by qualified personnel.

Before proceeding with the installation of this controller, read the instructions in this manual. Pay particular attention to precautions marked with the   symbol, related to the European Community directive on electrical protection and electromagnetic compatibility.



To prevent contact with electronically live components, **the controller must be installed in an enclosure or panel.**

2.1 GENERAL DESCRIPTION

IP 20 Terminal Block
EN61010 - 1 (IEC1010 - 1)

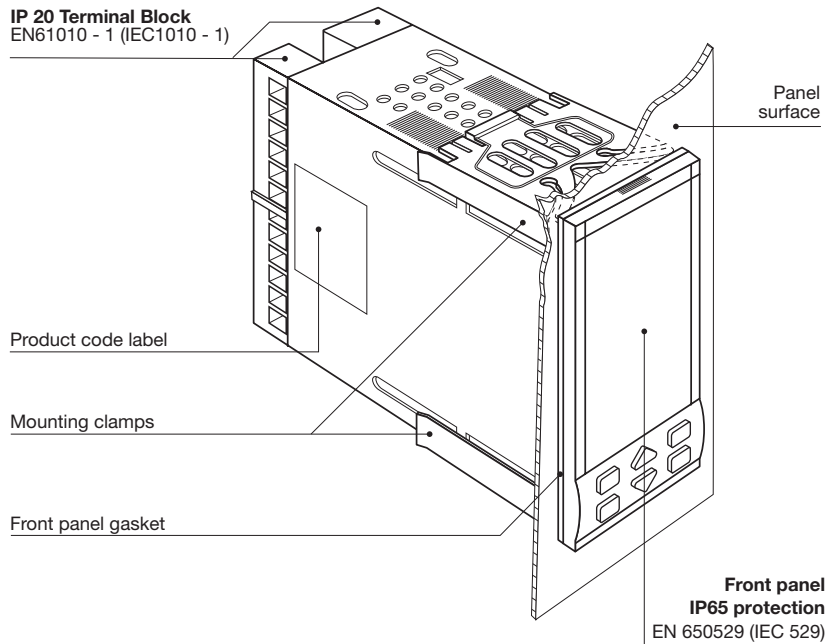

2.1.1 DIMENSIONAL DETAILS

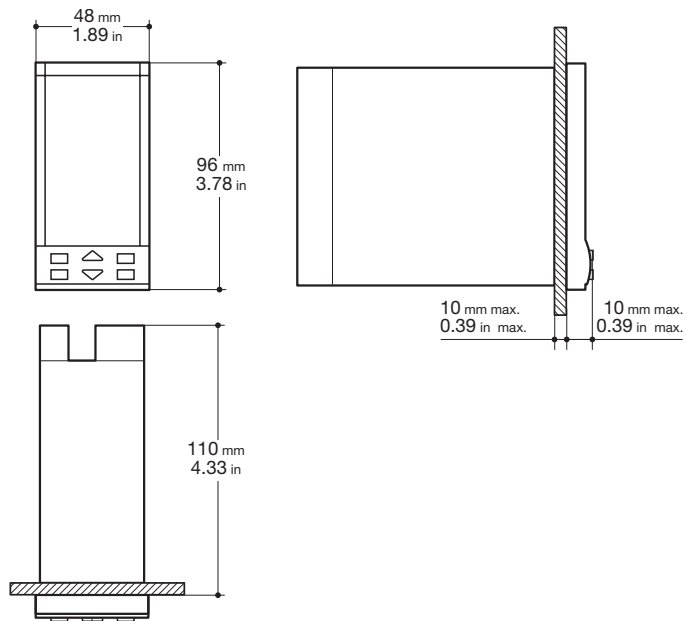

2.1.2 PANEL CUT-OUT

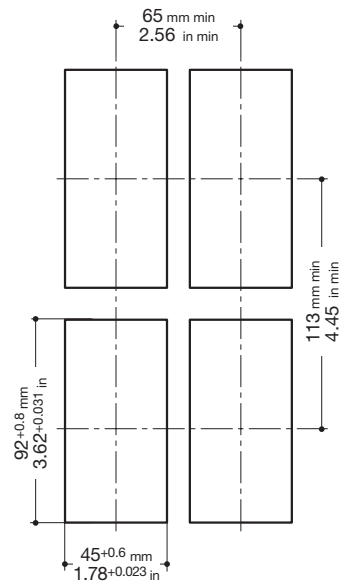

2.2 ENVIRONMENTAL RATINGS



Operating conditions



Altitude: up to 2,000 m

Temperature: 0...50°C **[1]**

%Rh

Relative humidity: 5...95 % non-condensing

Special conditions
Suggestions

Altitude: > 2,000 m

Use 24Vac supply version



Temperature: >50°C

Use forced air ventilation

%Rh

Humidity: > 95 %

Warm up



Conducting atmosphere

Use filter

Prohibited Conditions

Corrosive atmosphere



Explosive atmosphere

UL notes

**[1] Operating surrounding temperature
0...50°C**

2.3 PANEL MOUNTING [1]

2.3.1 INSERT THE INSTRUMENT

- 1 Prepare panel cut-out;
- 2 Check front panel gasket position;
- 3 Insert the instrument through the cut-out.

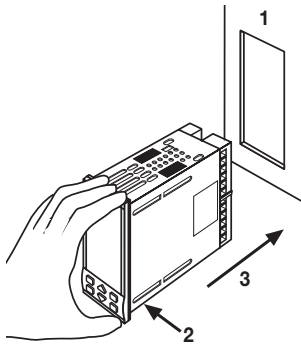

UL note

[1] For Use on a Flat Surface of a Type 2 and Type 3 'raintight' Enclosure.

2.3.2 INSTALLATION SECURING

- 1 Fit the mounting clamps;
- 2 Push the mounting clamps towards the panel surface to secure the instrument.

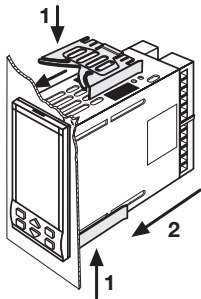

2.3.3 CLAMP REMOVAL

- 1 Insert the screwdriver in the clips of the clamps;
- 2 Rotate the screwdriver.

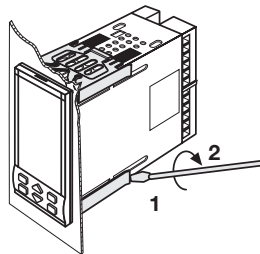

2.3.4 INSTRUMENT REMOVAL



- 1 Push and
- 2 Pull to remove the instrument.

Electrostatic discharges can damage the instrument.



Before removing the instrument the operator must discharge himself to ground.

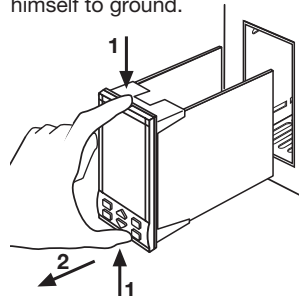

3 ELECTRICAL CONNECTIONS

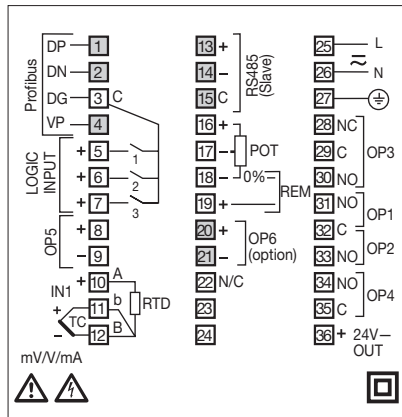

UL notes

- [1] Use 60/70 °C copper (Cu) conductor only.
 [2] Wire size 1 mm² (18 AWG Solid/Stranded)

3.1 TERMINAL BLOCK [1]

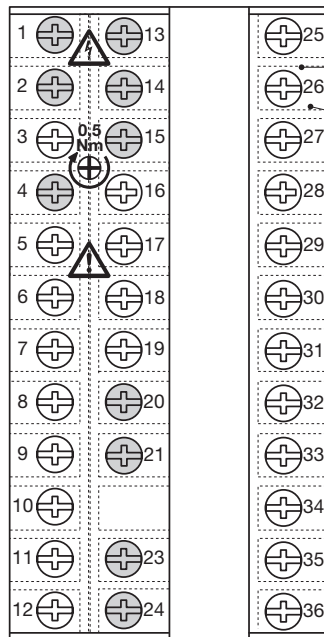

Rear terminal cover

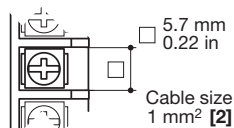

35 screw terminals M3



Option terminals



Holding screw 0.5 Nm



Phillips screwdriver PH1



Flat blade screwdriver
0.8 x 4 mm

Terminals

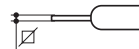

Pin connector
∅ 1.4 mm - 0.055 in max.



Fork-shape AMP 165004
∅ 5.5 mm - 0.21 in

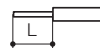

Stripped wire
L 5.5 mm - 0.21 in

PRECAUTIONS

The instrument has been designed to work in an harsh and noisy environmental (level IV of the industrial standard IEC 801-4). It is recommended to follow the following suggestions.



All the wiring must comply with the local regulations. The supply wiring should be routed away from the power cables. Avoid to place electro-magnetic contactors, power relays and high power motors nearby. Avoid power units in close proximity, especially if controlled in phase angle mode.

Keep the low level sensor input wires away from the power lines and the output wiring. If this is not achievable, use shielded cables on the sensor input, with the shield connected to ground.

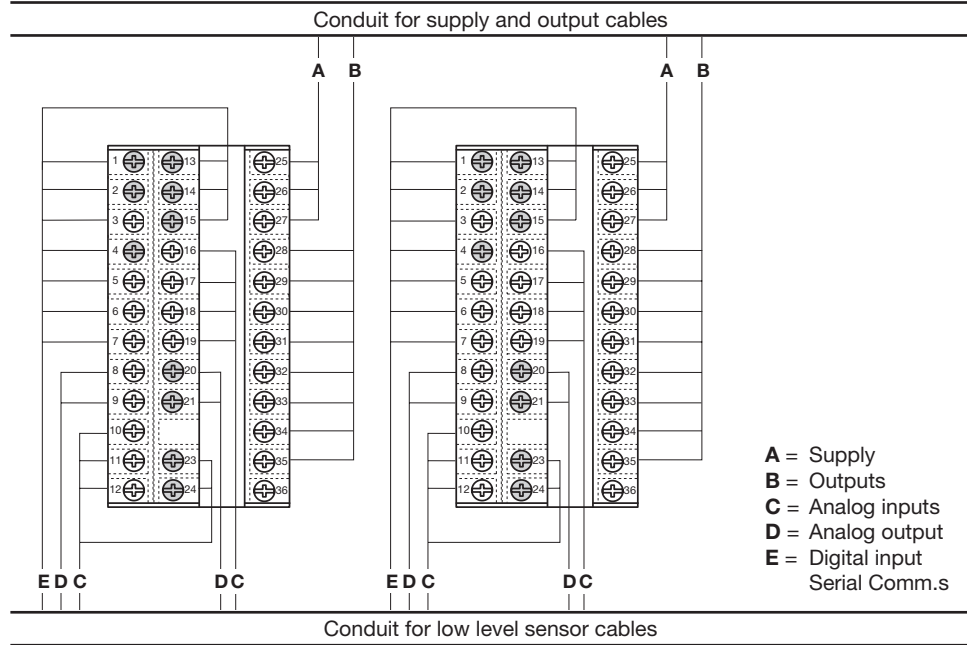
3.2 SUGGESTED WIRES ROUTING

3.3 EXAMPLE OF WIRING DIAGRAM (VALVE CONTROL)

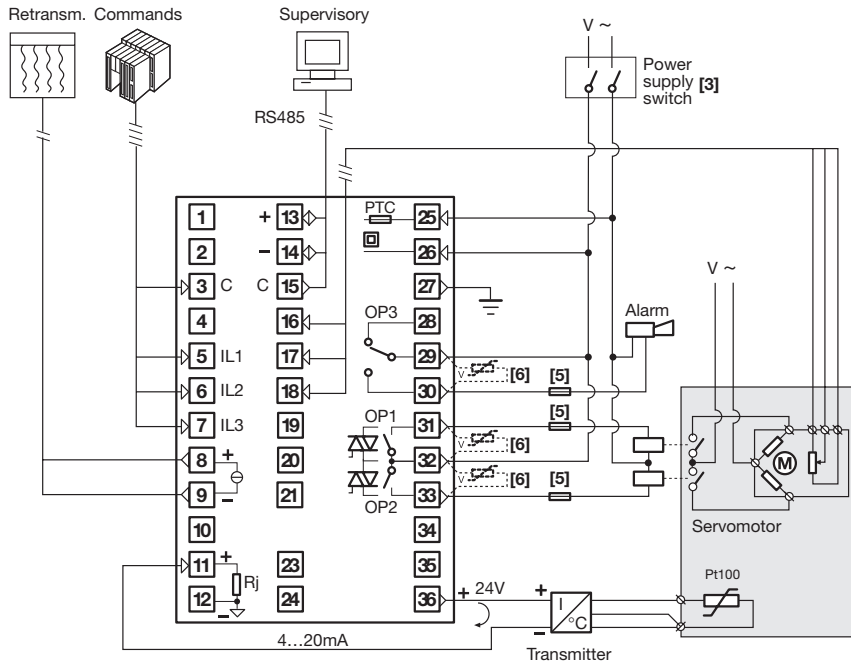
**Notes:**

- 1] Ensure that the power supply voltage is the same as that on the instrument label.
- 2] Switch ON the power supply only after all electrical connections have been completed.
- 3] In accordance with electrical safety regulations, there must be an easily identifiable and accessible power disconnect.
- 4] The instrument is PTC protected.
In case of failure, return the instrument to the manufacturer for repair.
- 5] To protect internal circuits use:
 - 2 A~ T fuse for Relay outputs (220 Vac)
 - 4 A~ T fuse for Relay outputs (110 Vac)
 - 1 A~ T fuse for Triac outputs
- 6] Relay contacts are protected with varistors.
In case of 24 Vac inductive loads, use model A51-065-30D7 varistors (on request).

3.3.1 POWER SUPPLY

Switching power supply with multiple isolation and PTC protection.

- **Standard version:**

Nominal voltage:

100... 240Vac (-15...+10%);

Frequency 50/60Hz.

- **Low Voltage version:**

Nominal voltage:

24Vac (-25...+12%);

Frequency 50/60Hz

or 24Vdc (-15...+25%);

Power consumption 5W max.

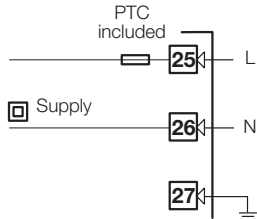

3.3.2 PV CONTROL INPUT

A L-J-K-S-R-T-B-N-E-W thermocouple type

- Connect wires with the polarity as shown;
- Always use compensation cable of the correct type for the thermocouple used;
- The shield, if present, must be connected to ground.

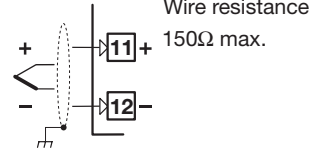

B For Pt100 resistance thermometer

- If a 3 wires system is used, always use cables of the same section (1mm² min.), maximum line resistance 20 Ω/line.
- When using a 2 wires system, always use cables of the same section (1.5mm² min.) and put a jumper between terminals 11 and 12

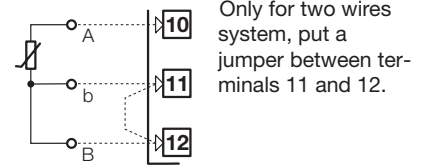

C For ΔT (2x RTD Pt100) Special

-  When the distance between the controller and the sensor is 15m, using a cable of 1.5mm² section, produces an error on the measure of 1°C.

R1 + R2 must be <320Ω

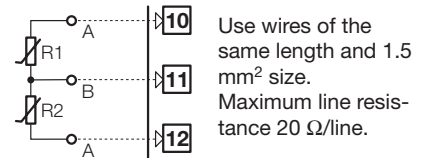

3.3.2 PV CONTROL INPUT

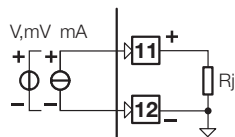
**C For mA, mV**

Input resistance = 30Ω per mA;

Input resistance > $10M\Omega$ per mV;

Input resistance = $10k\Omega$ per Volt;

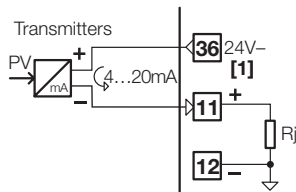
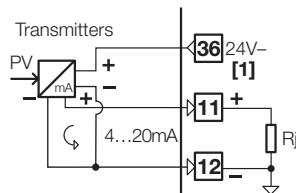
C1 With 2 wires transducer**C2 With 3 wires transducer**

[1] Auxiliary power supply for external transmitter 24Vdc $\pm 20\%$ /30mA max without short circuit protection.

3.3.4 AUXILIARY INPUT



A - From Remote Setpoint

Current 0/4...20mA;

Input resistance = 30Ω.

Voltage 1...5V, 0...5V, 0...10V;

Input resistance = 300kΩ.

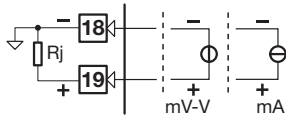

B - From Potentiometer

For the measure of the position of the motor or the valve.

100% **from 100Ω to 10kΩ max.**

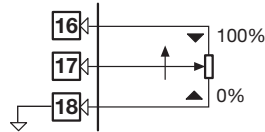
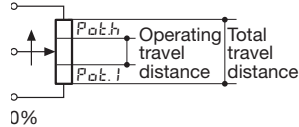

3.3.5 DIGITAL INPUT



- The input is active when the logic state is ON, corresponding to the contact closed.
- The input is inactive when the logic state is OFF, corresponding to the contact open.

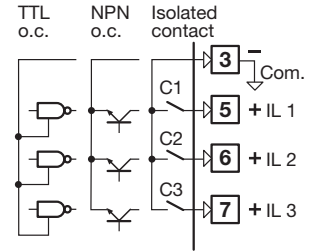

3.3.6 OP1 - OP2 - OP3 - OP4 - OP5 - OP6 OUTPUTS (OPTION)

The functionality associated to each of OP1, OP2, OP4, OP5 and OP6 is defined during the configuration of the instrument. The allowed combinations are:

	Control outputs		Alarms				Retransmission		
	Main (Heat)	Secondary (Cool)	AL1	AL2	AL3	AL4	PV / SP / MV		
A	Single action	OP1			OP2	OP3	OP4	OP5	OP6
B		OP5		OP1	OP2	OP3	OP4		OP6
D	Double action	OP1	OP2			OP3	OP4	OP5	OP6
E		OP1	OP5		OP2	OP3	OP4		OP6
F		OP5	OP2	OP1		OP3	OP4		OP6
G		OP5	OP6		OP2	OP3	OP4		
L	Valve drive	OP1 ▲	OP2 ▼			OP3	OP4	OP5	OP6

where:

OP1 - OP2	Relay or Triac output
OP3 - OP4	Relay outputs
OP5 - OP6	Analog control or retransmission outputs

3.3.6-A SINGLE ACTION RELAY (TRIAC) CONTROL OUTPUT

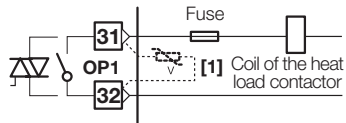

3.3.6-C DOUBLE ACTION RELAY (TRIAC)/RELAY (TRIAC) CONTROL OUTPUT

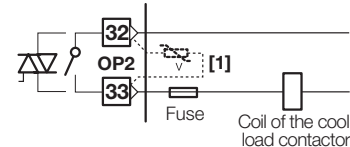
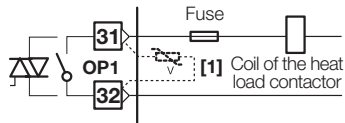

3.3.6-B1 SINGLE ACTION LOGIC CONTROL OUTPUT

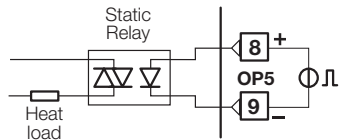

3.3.6-D1 DOUBLE ACTION RELAY (TRIAC)/LOGIC CONTROL OUTPUT

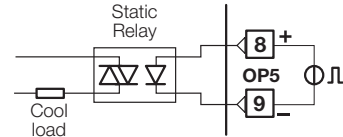
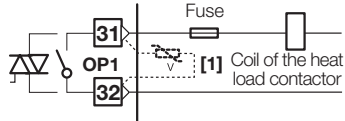

3.3.6-B2 SINGLE ACTION ANALOG OUTPUT

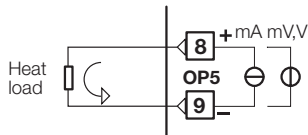

3.3.6-D2 DOUBLE ACTION CONTROL OUTPUT RELAY (TRIAC)/ANALOG CONTROL OUTPUT

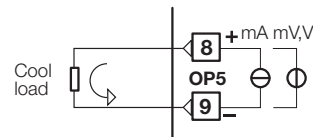
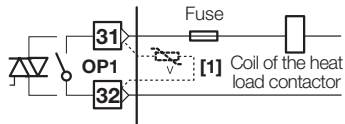

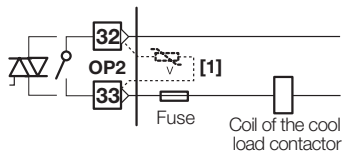
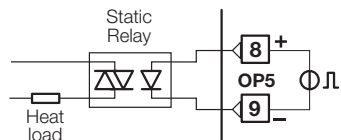
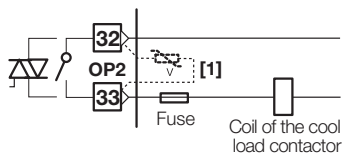
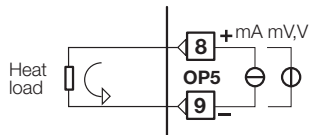
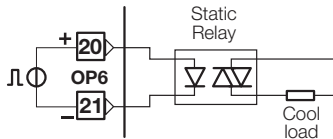
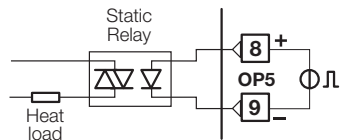
3.3.6-E1 DOUBLE ACTION**DIGITAL/RELAY (TRIAC) CONTROL OUTPUT****3.3.6-E2 DOUBLE ACTION****ANALOG/RELAY (TRIAC) CONTROL OUTPUT****3.3.6-F1 DOUBLE ACTION****DIGITAL/DIGITAL CONTROL OUTPUT****Notes for pages 17 - 18 - 19****OP1 - OP2 Relay output**

- SPST Relay N.O., 2A/250 Vac (4A/120Vac) for resistive load,
- Fuse 2A ac T at 250V, 4A ac T at 110V.

OP1 - OP2 Triac output

- N.O. contact for resistive load of up to 1A/250 Vac max.
- Fuse 1A ac T

Isolated digital outputs OP5-OP6

- 0...24Vdc, $\pm 20\%$, 30 mA max.

Isolated analog outputs OP5-OP6

- 0/4...20mA, 750 Ω / 15V max.
- 0/1...5V, 0...10V, 500 Ω / 20mA max.

[1] Varistor for inductive load 24Vac only

3.3.6-F2 DOUBLE ACTION CONTROL OUTPUT DIGITAL/ANALOG

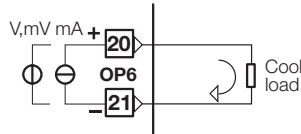
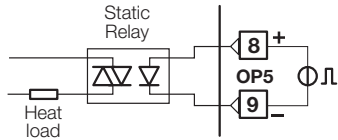

3.3.6-F3 DOUBLE ACTION CONTROL OUTPUT ANALOG/DIGITAL

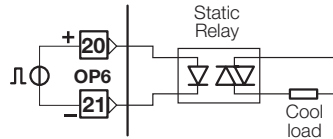
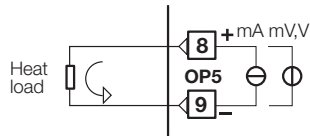

3.3.6-F4 DOUBLE ACTION CONTROL OUTPUT OR SPLIT RANGE ANALOG/ANALOG

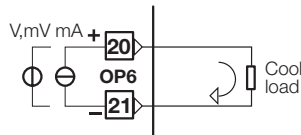
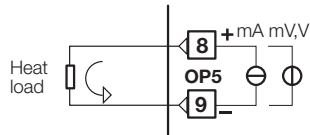

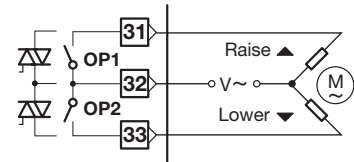

3.3.6-G MOTOR POSITIONER OUTPUT RELAY (TRIAC) / RELAY (TRIAC)

Valve drive PID **without** potentiometer 3 pole output with N.O. contacts (raise, lower, stop)

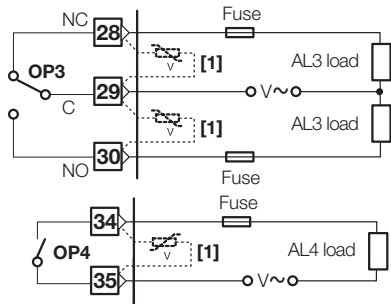

3.3.7 OP1-2-3-4 ALARM OUTPUTS



 **The relay/triac output OP1/OP2, can be used as alarm outputs only if they are not used as control outputs.**

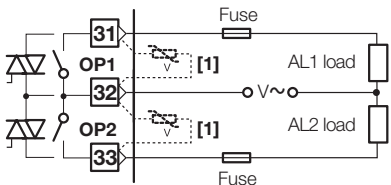

3.3.8 OP5 AND OP6 (OPTION) ANALOG CONTROL OUTPUTS

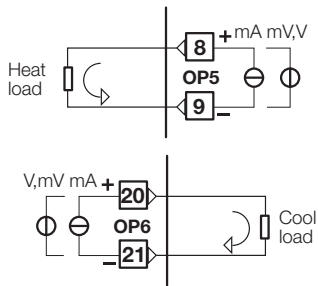

OP5 and OP6 can be configured for control action or PV/SP/MV retransmission:

- Galvanic isolation 500Vac/1 min;
- 0/4...20mA, 750Ω / 15Vdc max.
- 0/1...5V, 0...10V, 500Ω / 20mA max..

Notes:

[1] **Varistor for inductive load 24Vac only**

[2]  **Please, read the user manual: "Serial communications and configuration software".**

3.3.9 SERIAL COMMUNICATIONS (OPTION) [2]

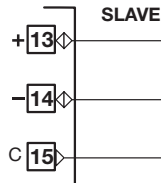

- Galvanic isolation 500Vac/1 min;
- Compliance to the EIA RS485 standard for Modbus/Jbus;
- Termination setting dip switches.

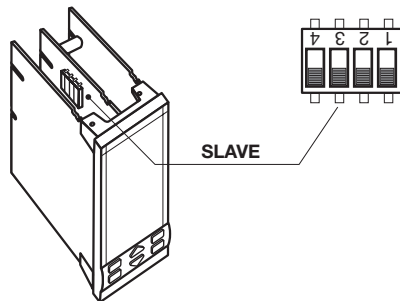



3.3.10 PROFIBUS DP (OPTION)

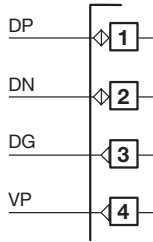

- Galvanic isolation 500 Vac/1 min
- Compliance to the EIA RS485 standard for PROFIBUS DP;
- Connecting cable: twisted pair cable as per PROFIBUS specifications (e.g. Belden B3079A);
- Max. length: 100 m at 12 Mb/s

Termination resistors 220Ω and 390Ω ($1/4$ W, $\pm 5\%$) for external mounting on the first and ending PROFIBUS stations only.

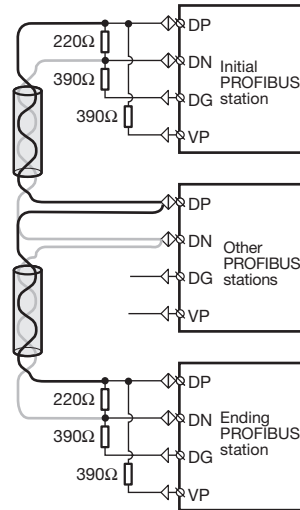

To make the connections easier, a D-Sub type (9 poles) connector, model **AP-ADP-PRESA-DSUB/9P** is provided. Must be used with a 9PIN male ERNI type part no. 103648 or similar connector.

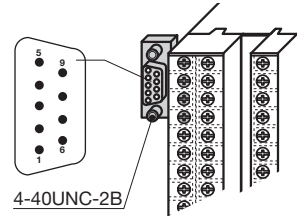

X5	D-SUB 9 poles	Signal	Description according to PROFIBUS specifications
1	3	RxD/TxD-P (DP)	Receive data/transmission data plus
2	8	RxD/TxD-N (DN)	Receive data/transmission data negative
3	5	DGND (DG)	Data transmission potential (ground to 5V)
4	6	VP (VP)	Supply voltage of the terminating resistance-P, (P5V)

Detailed information concerning wiring and cables can be found on the PROFIBUS Product Guide on Internet at:
<http://www.profibus.com/online/list>

4 OPERATION**4.1.1 KEY FUNCTIONS AND DISPLAYS IN OPERATOR MODE****Digital input status LEDs (yellows)**

- I 1** - IL1 active
- I 2** - IL2 active
- I 3** - IL3 active

Status LEDs (greens)

- SCI** Communications running
(serial communications interface)
- AT** Tuning running
- MAN** Manual operating mode
- RUN** Timer
- HLD** Program Waiting
- REM** Remote Setpoint active
- S1** First stored Setpoint active
- S2** Second stored Setpoint active
- S3** Third stored Setpoint active

Alarm status LEDs (reds)

- 1** AL1 ON
- 2** AL2 ON
- 3** AL3 ON
- 4** AL4 ON

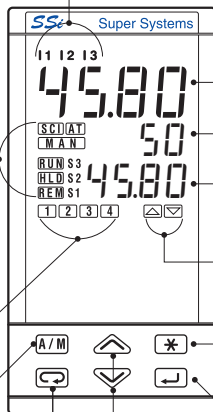
Auto/Man

Over range Under range

8888 8888

PV control input in engineering units

% Control output
or **Program status** (see page 64)

SP operating Setpoint
(Local/Remote or Stored)

Control output LEDs (red)

▲ OP1/OP4 ON - ▼ OP2/OP4 OFF

Run/stop Timer or a program

Entry key for selection and value setting confirmation

Setpoint setting

Menu access

4.1.2 KEY FUNCTIONS AND DISPLAY IN PROGRAMMING MODE



The parameter setting procedure has a timeout. If no keys are pressed for, at least 30 seconds, the controller automatically switches back to the operator mode.

After selecting the parameter or the code, press and to display or modify the value.

The value is entered when the next parameter is entered, by pressing the key.

The changes are not saved if either the back key is pressed or if the instrument is left alone for 30 seconds.

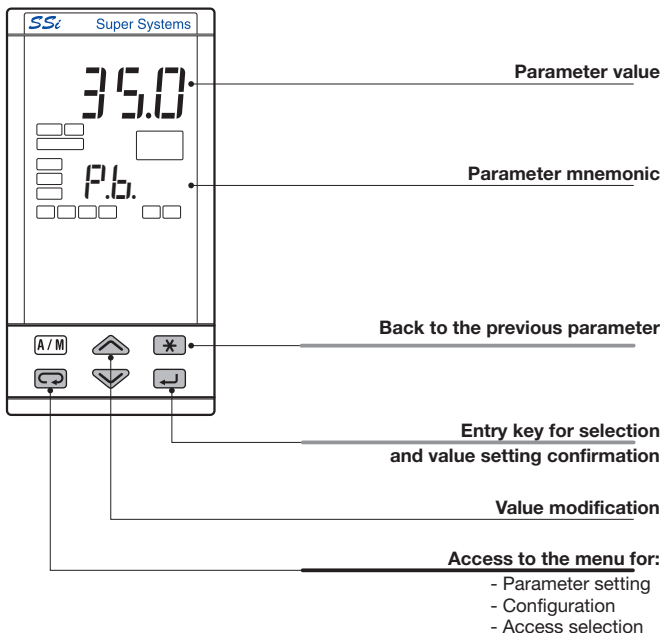

From every parameter, pressing the key, the controller switches to the operator mode.





4.2 PARAMETER SETTING

4.2.1 NUMERIC ENTRY



(i.e. the modification of the Setpoint value from 275.0 to 240.0)

Press  or  momentarily to change the value by 1 unit every push.

Hold  or  to change the value at rate that doubles every second.

The rate of change decreases when the button is released.



The change of the value stops when it has reached the max./min limit set for the parameter.

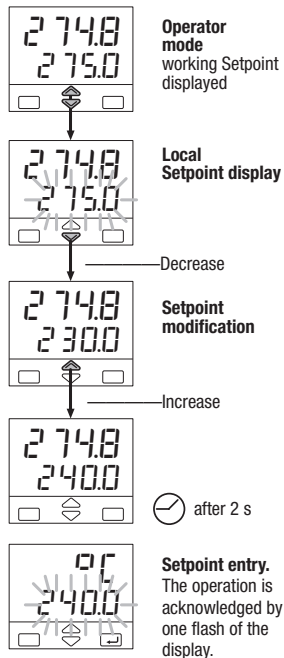

In case of Setpoint modification: press  or  once to display the local Setpoint instead of working Setpoint. To evidence this change the display flashes once. Then the Setpoint can be modified



4.2.2 MNEMONIC CODE SETTING

(e.g. configuration see page 26)

Press the  or  to display the next or previous mnemonic for the selected parameter.

Continued pressing of  or  will display further mnemonics at a rate of one mnemonic every 0.5 s. The mnemonic displayed at the time the next parameter is selected is the one stored and used.

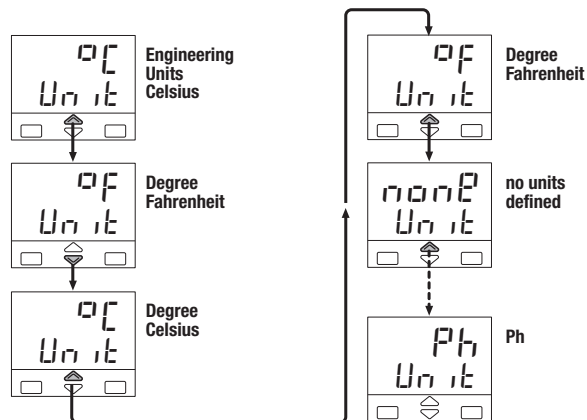

4.3 CONFIGURATION PROCEDURE

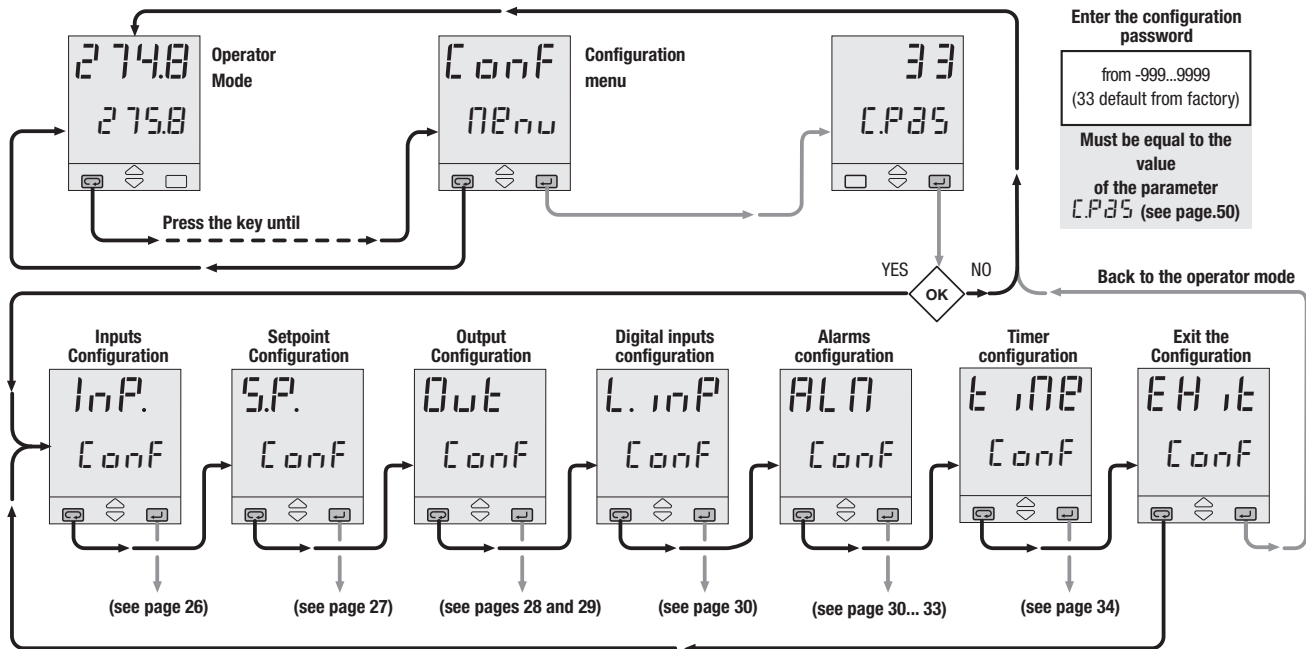

4.3.1 INPUTS CONFIGURATION

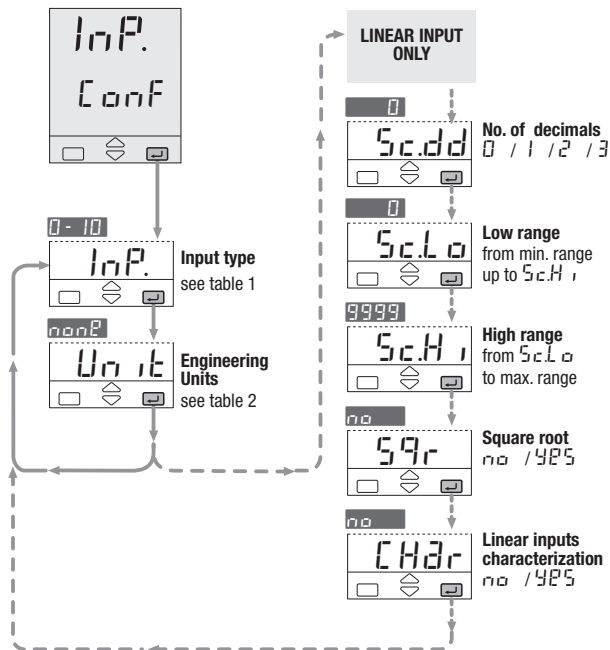

Tab. 1 Input type			
Value	Description	InP.	
tc_d	0...600°C	32...1112°F	
tc_e	0...1200°C	32...2192°F	
tc_L	0...600°C	32...1112°F	
tc_S	0...1600°C	32...2912°F	
tc_r	0...1600°C	32...2912°F	
tc_t	-200...400°C	-328...752°F	
tc_b	0...1800°C	32...3272°F	
tc_n	0...1200°C [1]	32...2192°F	
tc_n1	0...1100°C [2]	32...2012°F	
tc_U3	0...2000°C	32...3632°F	
tc_U5	0...2000°C	32...3632°F	
tc_E	0...600°C	32...1112°F	
cust	Custom range on request [3]		
rtd1	-200...600°C	-328...1112°F	
rtd2	-99.9...300.0°C	-99.9...572.0°F	
delt	-50.0...50.0°C	-58.0...122.0°F	
n50	0...50 mV	Engineering units	
n300	0...300 mV		
0-5	0...5 Volt		
1-5	1...5 Volt		
0-10	0...10 Volt		
0-20	0...20 mA		
4-20	4...20 mA		
Fr9L	0...2.000 Hz		Frequency (option)
Fr9H	0...20.000 Hz		

Tab. 2 Engineering units		
Value	Description	Unit
none	None	
°C	Degree centigrade	
°F	Degree Fahrenheit	
mA	mA	
mV	mV	
V	Volt	
bar	bar	
PSI	PSI	
Rh	Rh	
Ph	Ph	
Hz	Hertz	

Notes:

[1] NiChroSil-NiSil thermocouple.

[2] Ni-Mo thermocouple.

[3] Factory default for the custom range is: type K (32... 2448°F).

4.3.2 SETPOINT CONFIGURATION

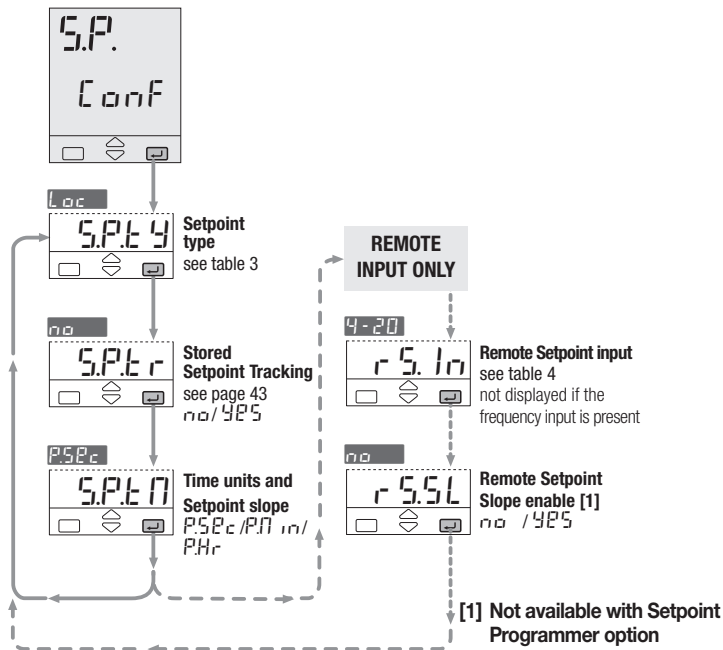
**Tab. 3 Setpoint type**

Value	Description	S.P.tY
Loc	Local only	
rPn	Remote only	
L-r	Local/remote only	
Loc.t	Local - trim	
rPn.t	Remote - trim	

Tab. 4 Rem. Setpoint

Value	Description	r.S.in
0-5	0...5 Volt	
1-5	1...5 Volt	
0-10	0...10 Volt	
0-20	0...20 mA	
4-20	4...20 mA	

4.3.3 OUTPUT CONFIGURATION

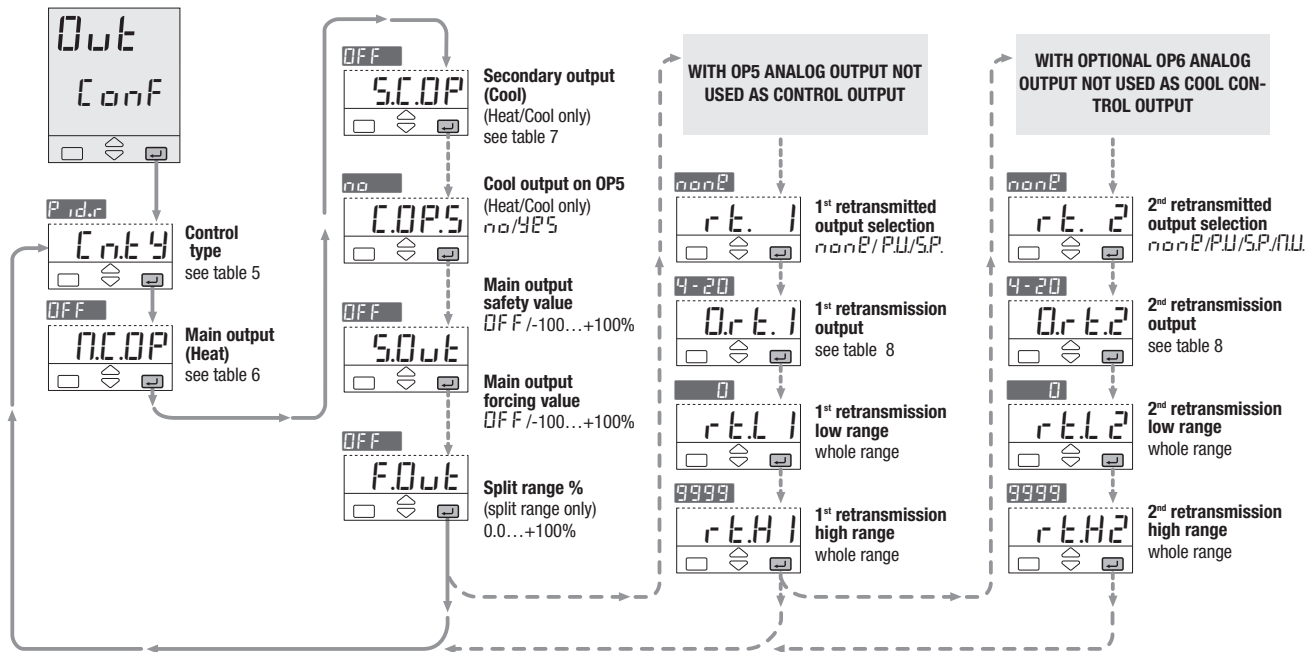

Tab. 5 Control mode		
Value	Description	CLTY
OF.rP	Reverse action	On - Off
OF.dI	Direct action	
P.rdd	Direct action	PID
P.rdr	Reverse action	
U.d.r	Direct action	Modul. valves
U.r.PU	Reverse action	
H.C.L.n	Linear	Heat/ Cool
H.C.O.L	Oil charac.	
H.C.H.2	Water charac.	

Tab. 6 Main Output (Heat)		
Value	Description	MLOP
OFF	Not used	
OP.1	Relay / Triac	Digital signal
L.0.9	Digital	DC signal
0-5	0...5 Volt	
1-5	1...5 Volt	
0-10	0...10 Volt	
0-20	0...20 mA	
4-20	4...20 mA	

Tab. 7 Secondary output (Cool)		
Value	Description	SLCP
OFF	Not used	
OP.2	Relay / Triac	Digital signal
L.0.9	Digital	DC signal
0-5	0...5 Volt	
1-5	1...5 Volt	
0-10	0...10 Volt	
0-20	0...20 mA	
4-20	4...20 mA	

Tab. 8 Retransmission outputs		
Value	Description	Ort.1 Ort.2
0-5	0...5 Volt	
1-5	1...5 Volt	
0-10	0...10 Volt	
0-20	0...20 mA	
4-20	4...20 mA	

RETRANSMISSION

When OP5 and OP6 outputs are not configured as control output, they can retransmit the PV, SP or MV linearized value.

Ort.1 **Retransmitted signal**
nonP/P.U./S.P/M.U.

Ort.2 **Output range**
0-5/1-5/0-10
0-20/4-20

The following parameters define the low and high range.

Ort.L1 **Retransmission low range**
Ort.L2

Ort.H1 **Retransmission high range**

Example:

- T/C S: range 0...1600°C;
- Output range, 4...20 mA;
- Retransmitted signal PV on 800...1200°C range.

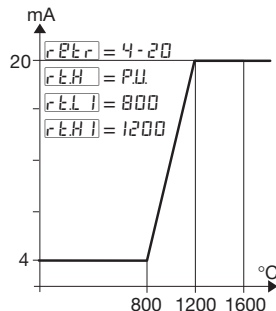

With **Ort.L1** greater than **Ort.H1** it is possible to obtain a reverse scale.

4.3.4 DIGITAL INPUT CONFIGURATION

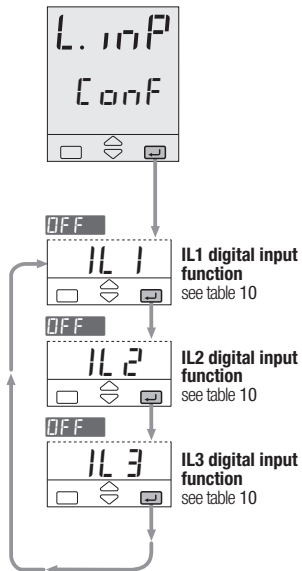

Value	Description	
OFF	Not used	IL 1
L-r	Local/Remote	IL 2
Auto/Man	Auto/Man	IL 3
S.P. 1	1 st stored Setpoint	
S.P. 2	2 nd stored Setpoint	
S.P. 3	3 rd stored Setpoint	
Keyb.l	Keyboard lock	
SLo.1	S.P. slope disable	
HPU	Measure hold	
FOut	Output forcing mode	
blck	Reset blocking	
Stk	Start-Hold timer	
trPS	Reset out timer	
End	Quit timer	

4.3.5 ALARM CONFIGURATION

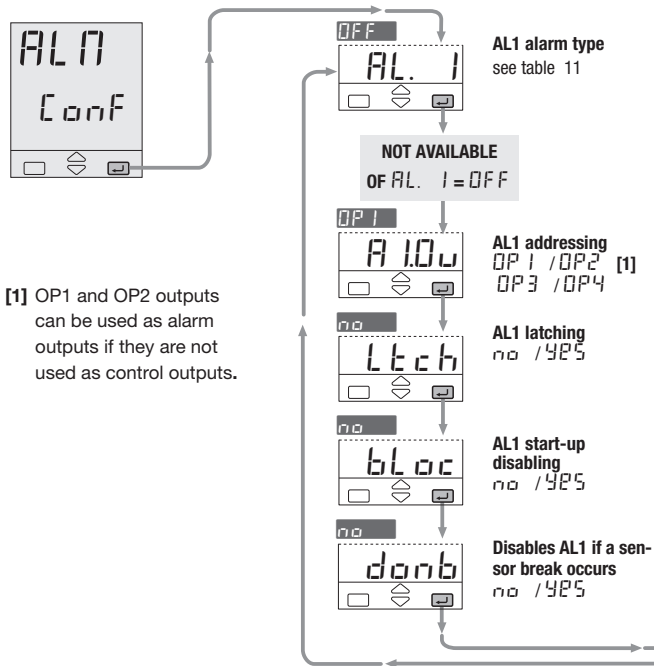

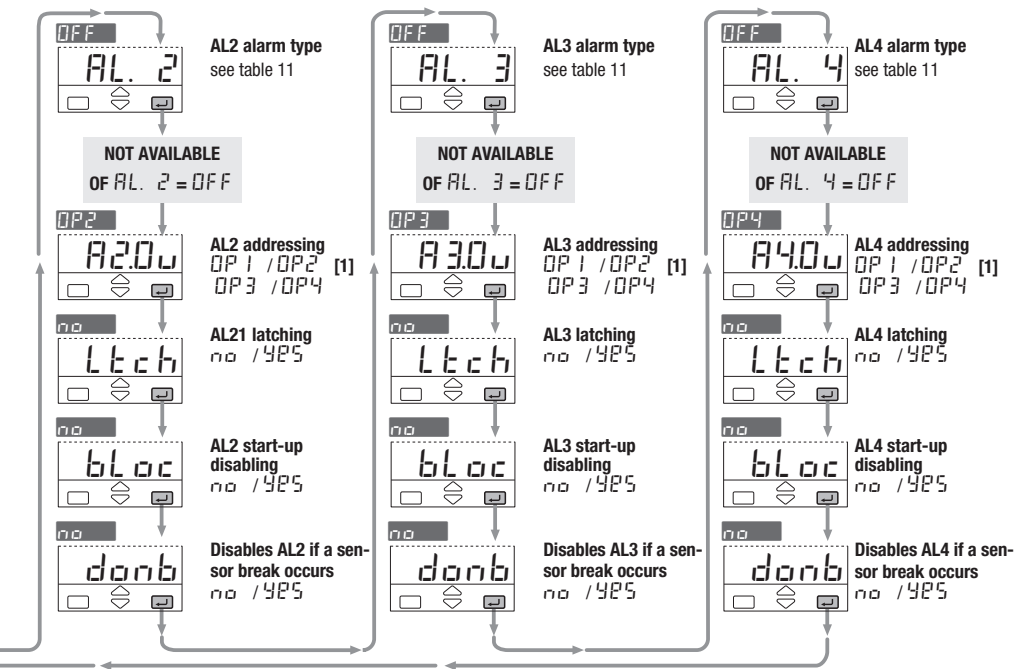

Value	Description	Alarm type	
		AL 1	AL 2
OFF	Not used or used by the program (AL3/AL4)	AL 3	AL 4
F5H	Active High	Absolute	
F5L	Active Low		
dPUH	Active High	Deviation	
dPUL	Active Low		
bno	Active Out	Band	
bni	Active In		
Lbd	Loop break alarm (AL1 only)		
t1nE	Alarm 3 active when Timer ON		

4.3.6 AL1, AL2, AL3, AL4 ALARM CONFIGURATION

Up to four alarms can be configured: AL1, AL2, AL3 and AL4 (see page 31).

For each alarm the following selections can be made:

A the type and the operating condition of the alarm (table 11 page 31)

B the functionality of the alarm acknowledge (latching) `Ltch`

C the start-up disabling (blocking) `blacc`

D alarm inhibition on sensor break

E the physical output of the alarm `OP1` `OP2` `OP3` `OP4`

The outputs can be used for alarms if they are not used as control outputs (see par. 3.3.7 page 20).

It is possible to route up to 4 alarm to a single output (OR of the alarms).

Alarm occurrence display

This function can be enabled by the configuration software.

Please, read the user manual:

“Serial communication and configuration software”.

The type of alarm is presented flashing, on the front panel in alternation with the PV value.

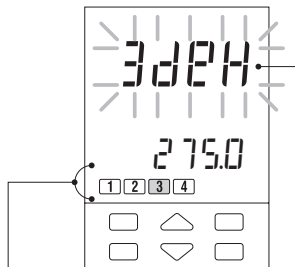

The red led of the activated alarm output is on.

[A] OPERATING CONDITIONS

Absolute alarm

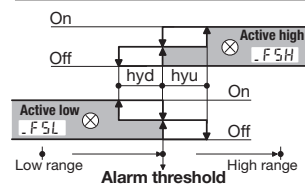

Deviation alarm

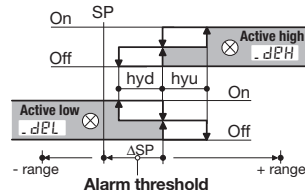

Band alarm

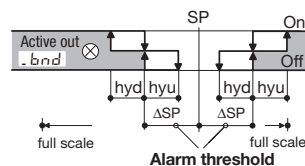

[B] ALARM ACKNOWLEDGE FUNCTION

The alarm, once occurred, is presented on the display until acknowledged. The acknowledge operation consists in pressing any key.

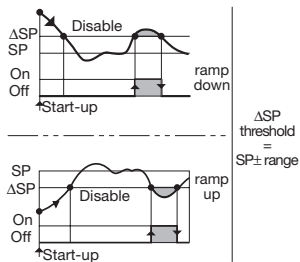
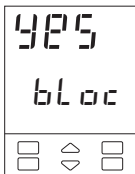

After this operation, the alarm leaves the alarm state only when the alarm condition is no longer present.

[C] START-UP DISABLING**[D] ALARM DISABLING AT SENSOR BREAK**

For those alarms that are configured to be different than LBA, it is possible to set the parameter `donb` (disable on break).

Set:

- `no` To maintain the alarm status when a sensor break is detected.
- `425` To disable the alarm intervention when a sensor break is detected. Once the sensor has been changed, the alarms that were active before the sensor break are activated again.

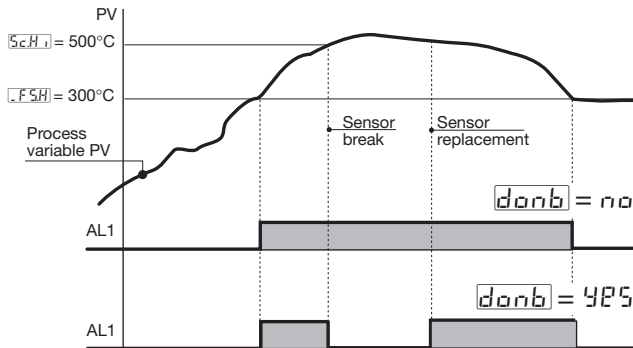
**LOOP BREAK ALARM (LBA)**

When the controller connection to the sensor is discontinued or other faults are detected in the control loop, AL1 alarm becomes active after a predefined time of 1... 9999 s from the detection of the failure (see page 37). When a sensor failure occurs, the LBA intervention is immediate. The alarm state ceases when the fault condition is no longer present.

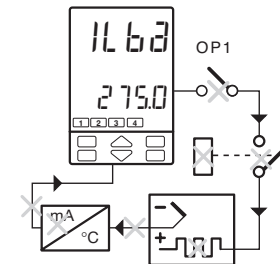



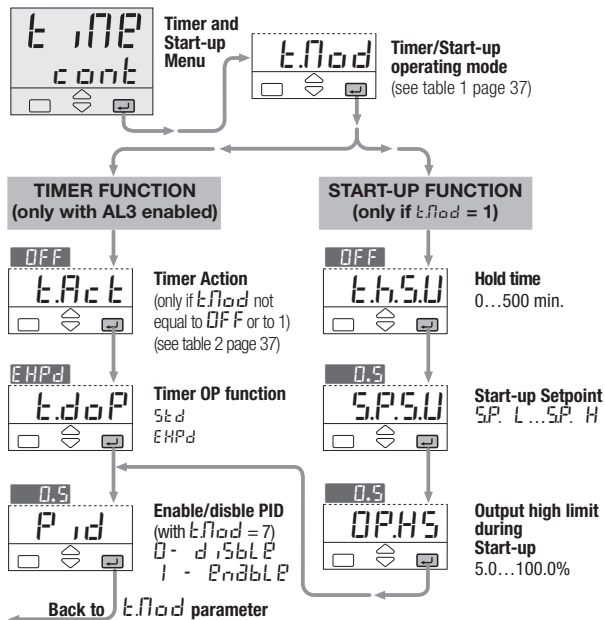

⚠ In case of ON-OFF control, the LBA alarm is not active.

4.3.7 TIMER CONFIGURATION

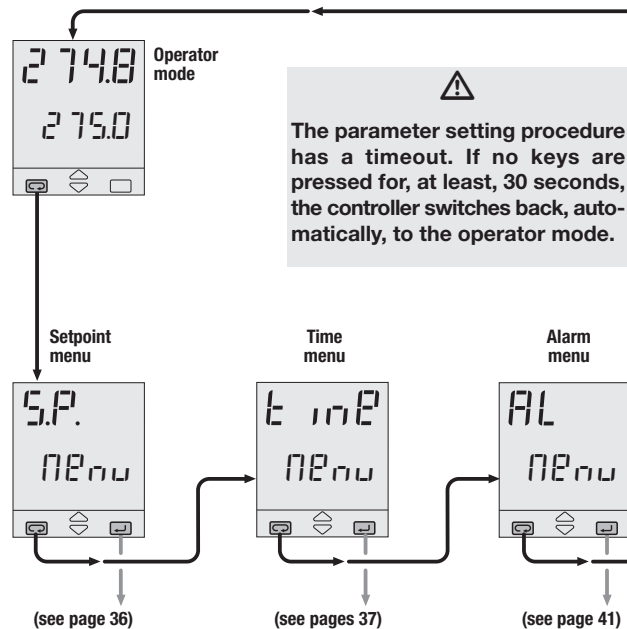

4.4 PARAMETERIZATION - MAIN MENU



After having selected the parameter or the code, press  or  to modify the value (see page 24) The value is entered when the next parameter is entered, by pressing the  key.

Pressing  go back to the Operator mode

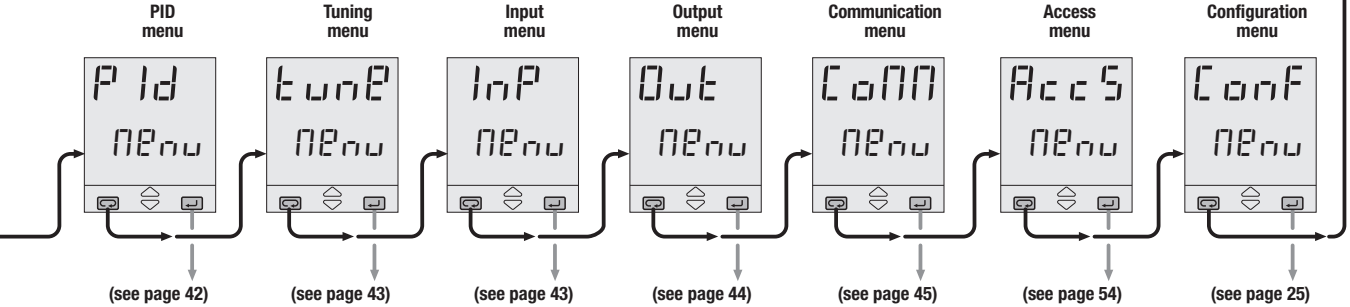

4.4.1 PARAMETERIZATION - SETPOINT MENU

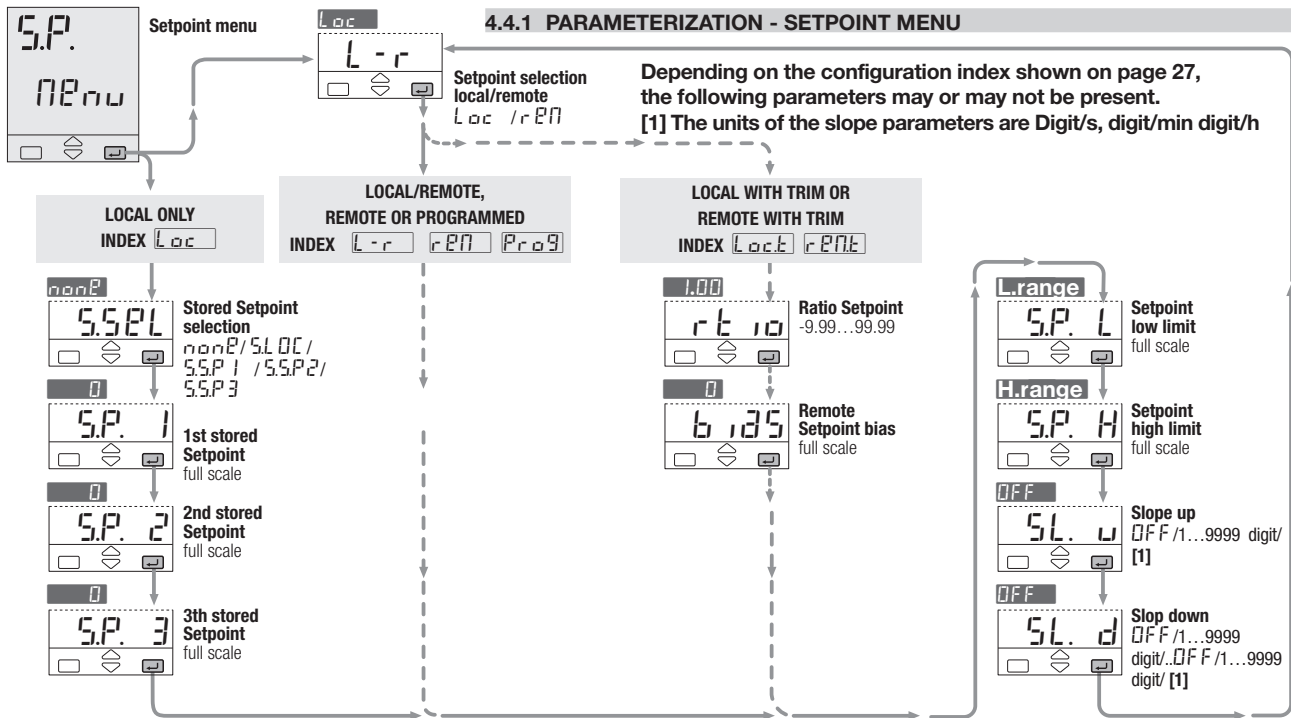

4.4.4.2 TIMER FUNCTION

⚠ The Timer cannot be enabled with Heat/Cool control.

To enable this function, perform the following:

- 1 In order to use this AL3 function, index **Q** must be set to **1** in configuration (see page 22)
- 2 To select one of the 6 possible functioning modes of the Timer, set the value of the following 2 parameters in parameterization (see p. 29).

t.Mod Timer/Start-up operating mode

This parameter can be defined: (see table 1)

- counting start time
- control output status at the end of the counting

table 1

Timer/Start-up counting mode		Value
Disabled		0FF
Start-up function		1
Counting start time	End mode	
When inside the band	Control mode	2
	Output to 0	3
When launched	Control mode	4
	Output to 0	5
When launched. Control disabled	Control mode	6
	Control mode	7
When launched stand-by Setpoint	Control mode	7

Now the other parameter values can be entered:

t.Act Timer Action

This parameter can be defined: (see table 2)

- time units
- starting mode
- OP3 status when the timer is running.

When the timer is not running, the OP3 takes the opposite status.

table 2

Time units	Starting mode	[1] OP3 status	Value
Minutes	Manual by keypad	On	4
		Off	5
	Auto at Power ON [2]	On	6
		Off	7

[1] If used by Timer

[2] Using this selection, manual starting mode is also possible.

t.dOP Timer OP function

5t.d/PHPd

standard/extended

Standard: $t.dOP = 0$

OP3 is set to 1 at timer launch and reset 0 on time elapsing.

Extended: $t.dOP = 1$

OP3 is set to 1 at time elapsing and set to 0 by reset command.

Pid P.I.D enable

4P5/no

Yes:

PID is enabled when time function is enabled.

Extended:

PID is disabled and output is maintained at zero.

4.4.4.2 TIMER FUNCTION

TIMER COUNTING MODES

A - Counting start time inside the band, end in control mode.

The time counting starts only when the error is inside a ± 1 digit band. The control action is not affected by the Timer function.

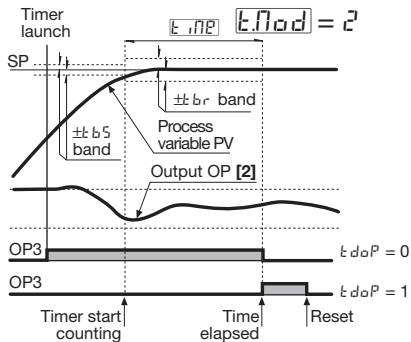
**B - Counting start time inside the band, end with control output forced to zero.**

The time counting starts only when the error is inside a ± 1 digit band. At the end, the control output is forced to zero [1].

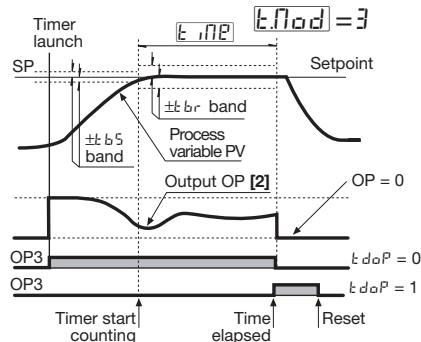
**C - Counting start time = timer launch time, end in control mode.**

The time counting starts when the timer is launched. The control action is not affected by the Timer function.

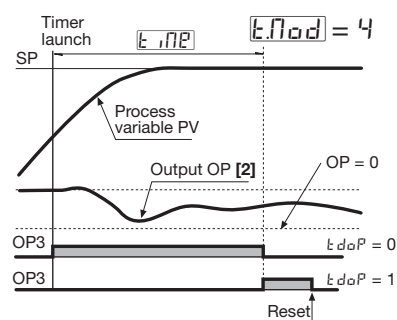
**Notes**

[1] When the Timer is not running the control output is forced to zero.

[2] When the PID enable parameter is set to "0" (PID disabled) the OP output is set to "0".

TIMER COUNTING MODES

D - Counting start time = timer launch time, end with control output forced to zero.

The time counting starts when the timer is launched. At the end, the control output is forced to zero [1].

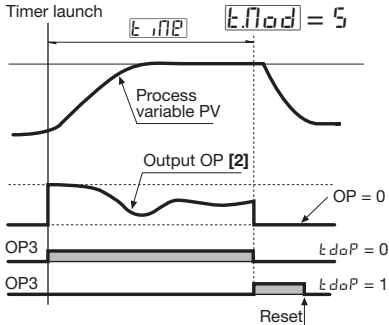

E - No control action during the counting time.

The time counting starts when the timer is launched and the control output is forced to zero. At the end, the control action starts.

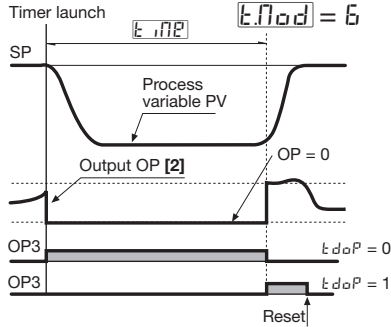

F - Control action with stand-by Setpoint during the counting time.

The time counting starts when the timer is launched and the control action use the Stand-by Setpoint. At the end, the control action use the working Setpoint.

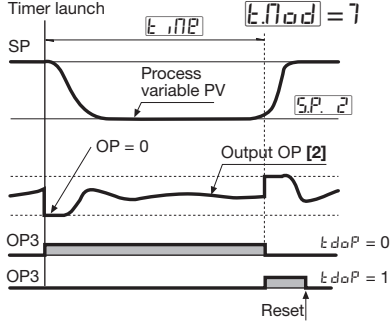

Notes

- [1] When the Timer is not running the control output is forced to zero.
- [2] When the PID enable parameter is set to "0" (PID disabled) the OP output is set to "0".

4.4.4.2 TIMER FUNCTION (OPTION)

POWER FAILURE

If there is a power failure during the Timer execution, the value of the elapsed time is lost.

Depending on Timer action t_{act} selection, when the controller restarts you can have two different situations:

- with automatic mode

($t_{act} = 6, 7$), the Timer function starts again and the counting time is re-initialized.

- with manual mode

($t_{act} = 4, 5$), the control output is forced to zero, if $t_{mod} = 3 e 5$; otherwise the control action restarts using the working Setpoint

TIMER START

See the Timer starting procedure on page 50 (chapter 6.2.2)

DISPLAY

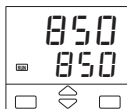

When the Timer is running, the **RUN** LED is on.



TIMER REMAINING TIME

When the timer is running it is possible to see the remaining time and to modify it.

To change the value of **Time Remaining**, it is necessary to put (from the t_{inE} menu) the parameter t_{5t5} in **HOLD**.

When the user exits the menu, it is possible through the up (\wedge) and down (\vee) keys to change the **Time Remaining**.

To restart the timer, select the t_{5t5} parameter in Time Menu and set it to **RUN**.

4.4.2 PARAMETERIZATION - ALARMS MENU

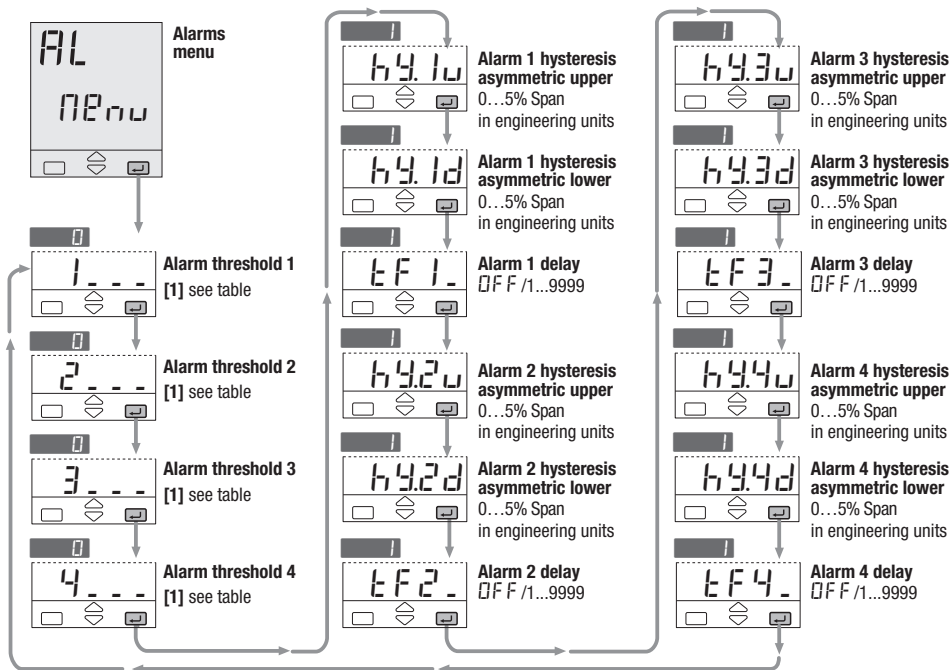

[1] A code, specifying the No. and the alarm type that has been configured (see page 31), is displayed. At this point, the user must enter the threshold value, according to the following table.

Type and value	Mode	No. and Param.
Absolute full scale	Active high	<code>_F5H</code>
	Active low	<code>_F5L</code>
Deviation full scale	Active high	<code>_dPH</code>
	Active low	<code>_dPL</code>
Band full scale	Active out	<code>_bno</code>
	Active in	<code>_bn i</code>
L.B.A. 1...9999 s	Active high	<code>_Lb2</code>
Timer ON on timer signal	Alarm 3 active on timer signal	<code>-ton</code>

4.4.3 PARAMETERIZATION - PID MENU (not shown for ON-OFF control action)

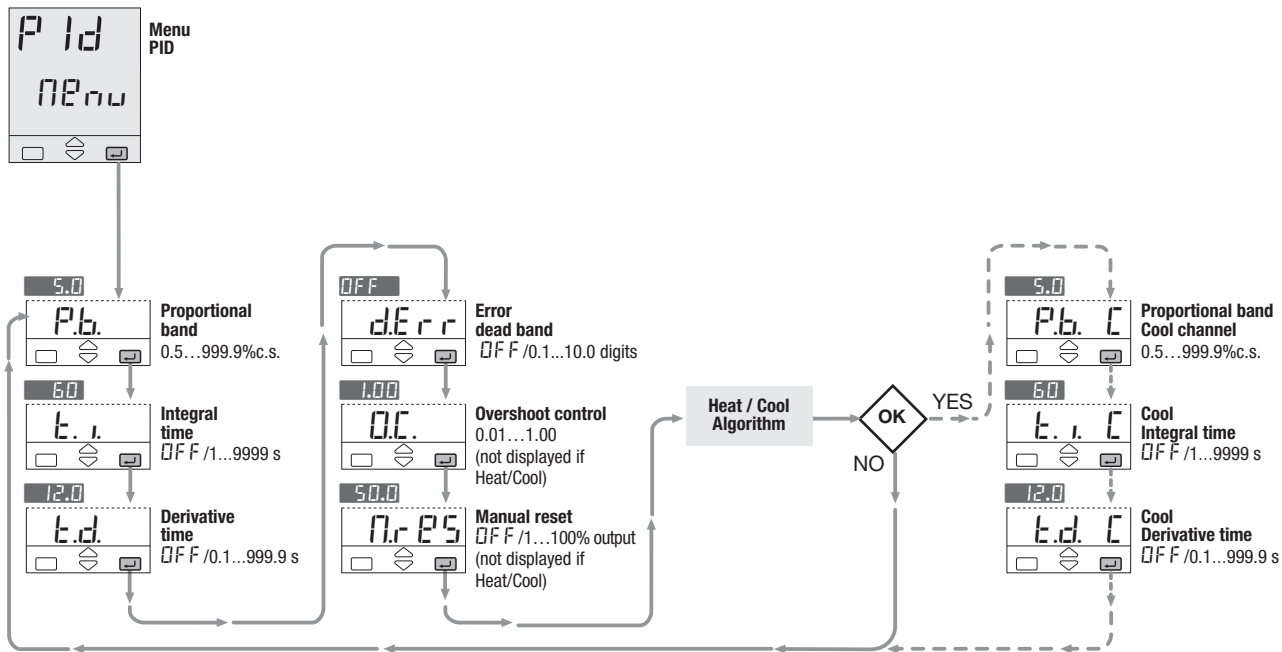

4.4.4 PARAMETERIZATION

TUNING MENU (not shown for ON-OFF control action)

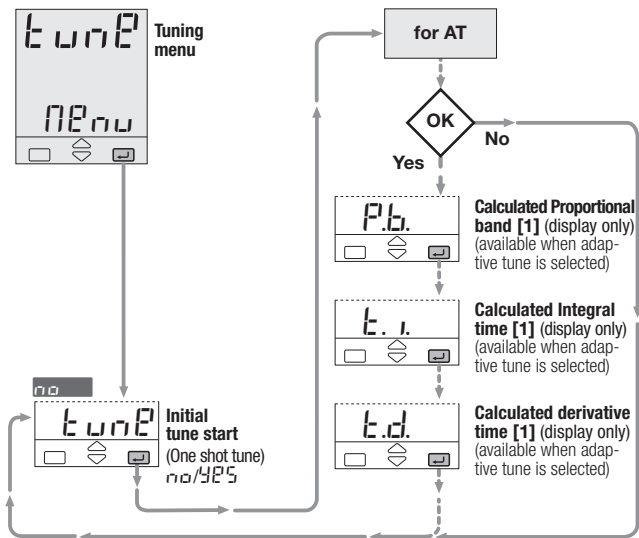

[1] These values are not automatically stored on the PID menu parameters *P.b.*, *t.i.*, *t.d.*

4.4.5 PARAMETERIZATION

INPUT MENU

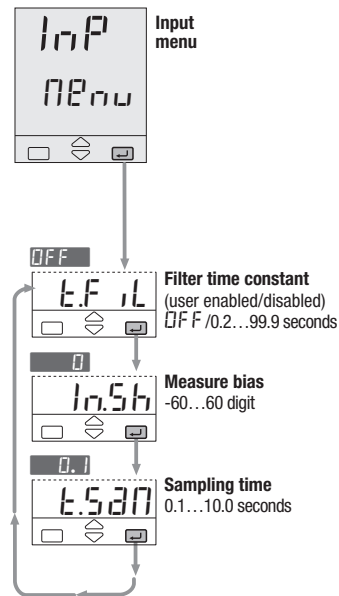

4.4.6 PARAMETERIZATION - OUTPUT MENU

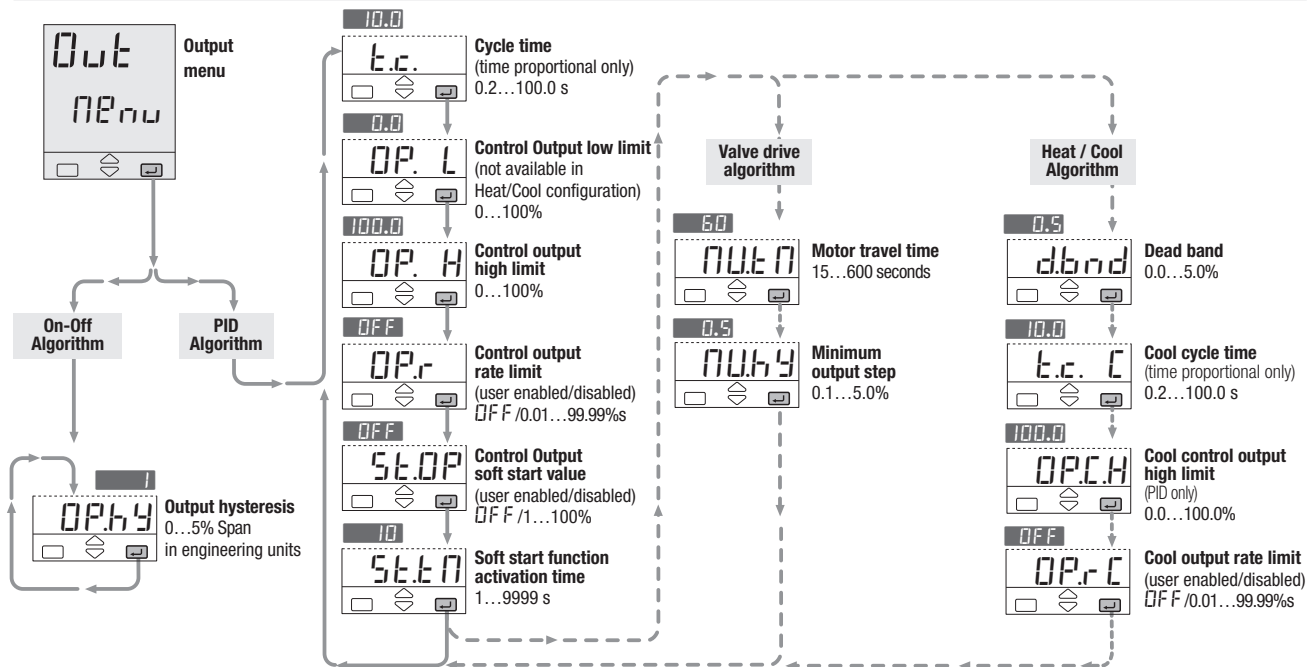

4.4.7 PARAMETERIZATION - SERIAL COMMUNICATION MENU

Depending on serial communication chosen (see model code on page 5), there are the following parameters:

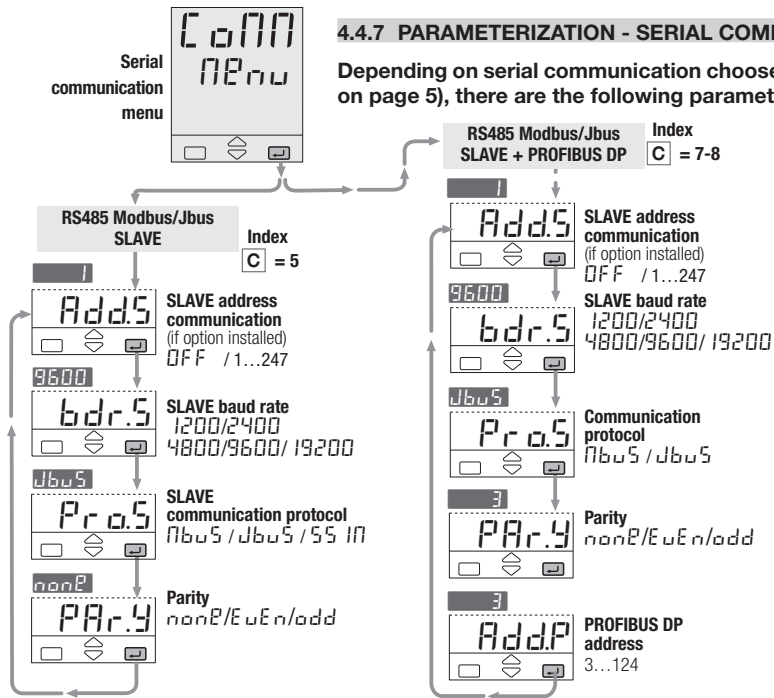

4.5 PARAMETERS

For a simpler use of the controller, the parameters have been organized in menus, according to their functional area.

S.P. L

**Setpoint
low limit**

S.P. H

**Setpoint
high limit**

High and low limit of the SP.
The minimum span (S.P.L - S.P.H)
must be greater than 100 digit.

SL. u

**Setpoint
ramp up**

SL. d

**Setpoint
ramp down**

This parameter specifies the
maximum rate of change of the
Setpoint.
Adjustable in digit/s, digit/min
and digit/hour (see page 27)

When the parameter is OFF, this function is disabled and the new Setpoint is reached immediately after being entered.

4.5.1 SETPOINT MENU

Otherwise, the Setpoint value is obtained according to the configured rate of change.

The new Setpoint value is called "Target Setpoint". It can be displayed by means the parameter **E.SP.** (see procedure at page 53).

When Remote Setpoint is configured, we suggest to disable **SL.u** and **SL.d** parameters **OFF**.

Example

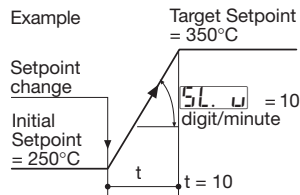

S.P. 1

**1st stored
Setpoint**

S.P. 2

**2nd stored
Setpoint**

S.P. 3

**3th stored
Setpoint**

Values of the three Setpoints, that are activated by mean of logic inputs, communication parameters, and keyboard. The Setpoint active is indicated by the **S1**, **S2** or **S3** green LED.

See page 56 for further explanation.

r S.SL

**Remote Setpoint
Slope enable**

To enable or disable slopes when the remote Setpoint is active.

SPTr

Stored Setpoint Tracking

(see chapter 4.3.2 at page 27)
Two different operation mode can be set:

A Stand-by mode **no**

The selection of any memorized SP (SP1, SP2, SP3) does not overwrite the previous local Setpoint when the memorized SP is no longer active. The previous local SP is unchanged.

B- Tracking mode **yes**

The use of any memorized SP (SP1, SP2, SP3) overwrites the local SP value.

The previous Local Setpoint value will be lost.

rt 10

Remote Setpoint Ratio

Ratio is the coefficient which defines the remote Setpoint span with respect to the input span.

b 125

Remote Setpoint

Bias defines the starting point of analog Remote Setpoint in engineering units corresponding to the low limit (current or voltage) of the remote signal.

Remote Setpoint Bias and Ratio

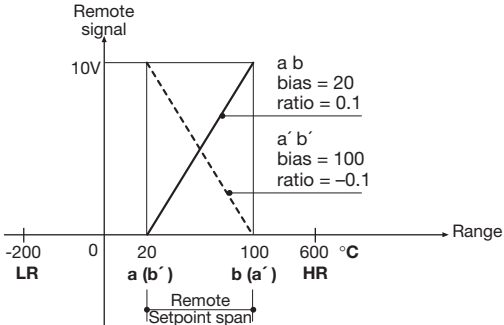

- PV = Process Variable
- LR = PV low limit
- HR = PV high limit
- SR = Remote Setpoint
- a(a') = SR starting point
- b(b') = SR ending point

4.5.1 SETPOINT MENU

If SR starting point is **lower** than the ending point, both expressed in engineering units:

b_{start} = starting point = a

$$r_{\text{trim}} = \frac{b - a}{\text{HR} - \text{LR}}$$

E.g.: $b_{\text{start}} = 20$

$$r_{\text{trim}} = \frac{100 - 20}{600 - (-200)} = \frac{80}{800} = 0.1$$

If SR starting point is **higher** than the ending point, both expressed in engineering units

b_{start} = starting point = a'

$$r_{\text{trim}} = \frac{b' - a'}{\text{HR} - \text{LR}}$$

E.g.: $b_{\text{start}} = 100$

$$r_{\text{trim}} = \frac{20 - 100}{600 - (-200)} = \frac{-80}{800} = -0.1$$

Working Setpoint (SP) as combination of Local Setpoint (SL) and remote signal

Setpoint L_{offset} (table 3, page 27)

$$\text{SP} = \text{SL} + (r_{\text{trim}} \cdot \text{REM}) + b_{\text{start}}$$

Setpoint r_{trim} (table 3, page 27)

$$\text{SP} = \text{REM} + (r_{\text{trim}} \cdot \text{SL}) + b_{\text{start}}$$

SIGN = Remote signal %

SPAN = HR-LR

$$\text{REM} = \frac{\text{SIGN} \cdot \text{SPAN}}{100}$$

E.g.: Local Setpoint (SL) with an external Trim with multiplying coefficient of 1/10:

Setpoint type = L_{offset}

$r_{\text{trim}} = 0.1$; $b_{\text{start}} = 0$

Remote Setpoint (SR) with an internal Trim with multiplying coefficient of 1/5:

Setpoint type = r_{trim}

$r_{\text{trim}} = 0.2$; $b_{\text{start}} = 0$

Remote Setpoint range equal to the Input range:

Setpoint type = L_{offset}

$r_{\text{trim}} = 1$; $b_{\text{start}} = \text{LR}$

$SL = 0$

4.5.2 ALARM MENU

(see also pages 32 and 33)

h3.u

Asymmetric upper alarm hysteresis

h3.d

Asymmetric lower alarm hysteresis

EF1

Alarm delay

Delay time for alarm activation.
 DFF : alarm activated immediately
 1...9999 seconds: alarm activated only if the condition persists for the set time

Example with high absolute alarm

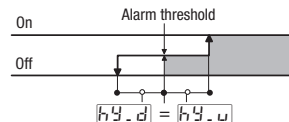

The parameter can be set between 0 and 5% of the configured Span and set in Engineering units. e.g.

Range = -200...600°C

Span = 800°C

Max. Hysteresis = 5% 800° = 40°C

For symmetrical hysteresis set

h3.d = h3.u

4.5.3 PID MENU

Not present with On-Off main output or Timer PID = 0.

P.b. Proportional Band

P.b. C Cool Proportional Band

This parameter specifies the proportional band coefficient that multiplies the error (SP - PV)

E. I. Integral Time

E. I. C Cool integral Time

This is the integral time value that specifies the time required by the integral term to generate an output equivalent to the proportional term. When $\square F F$, the integral term is not included in the control algorithm.

E.d. Derivative Time

E.d. C Cool Derivative Time

This is the time required by the proportional term P to reach the level of D. When $\square F F$ it is not included in the control algorithm.

O.C. Overshoot control

(Automatically disabled when the adaptive tune is running)

This parameter specifies the span of action of the overshoot control. Setting lower values (1.00—>0.01) the overshoot generated by a Setpoint change is reduced. The overshoot control doesn't affect the effectiveness of the PID algorithm. Setting 1, the overshoot control is disabled.

0.r 25 Manual reset

This term specifies the value of the control output when PV = SP, in a PD only algorithm (lack of the Integral term).

d.e r r Error Dead Band

Inside this band for (PV - SP), the control output does not change to protect the actuator (output Stand-by).

4.5.4 TUNING MENU

(not shown for ON-OFF main control output)

See page also 57

Two tuning method are provided:

- Initial one shoot **Fuzzy-Tuning**
- Continuous, self learning **Adaptive Tuning**

The **Fuzzy-Tuning** automatically determines the best PID term with behaviour respect to the process.

The controller provides 2 types of "one shot" tuning algorithms, that automatically are selected according to the process conditions when the tune operation is started.

STEP response

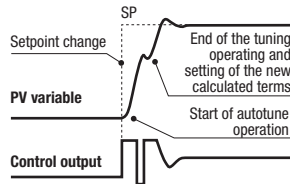

Fuzzy-Tuning is selected when, at the start of the autotune operation, the PV is far from the Setpoint (more than 5% of the span). This method has the advantage of fast calculation with a reasonable accuracy in the term calculated.

Natural frequency

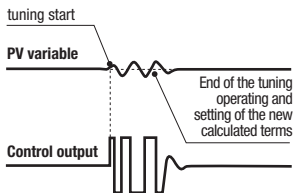

Natural frequency is selected when the PV is close to the SP.

This method has the advantage of better accuracy in the terms calculated with reasonable speed.

The Fuzzy Tuning automatically determines the best method to use to calculate the PID term, according the

process conditions.

The self-learning **adaptive auto-tune** is not intrusive. It does not affect the process during the phase of calculation.

Continuous adaptive tune

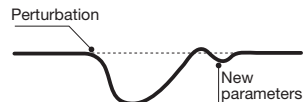

Continuous adaptive tune is particularly suitable for controlling process whose control characteristics change with time or are not linear in relation to the Setpoint values.

It does not require any operation by the user. It continuously samples the process response to the various perturbations, determining the frequency and the amplitude of the signals. On the basis of this data and their statistical values stored in the instrument,

it modifies the PID term parameters.

It is the ideal for all applications where it is required to continuously change the PID terms parameters in order to adjust the PID to the changes of the process dynamic conditions.

In case of power OFF with the Adaptive Tune enabled, the values of the PID terms parameters are stored, in order to be reused at the next power ON.

At power on the Adaptive Tune starts automatically.

4.5.5 INPUT MENU

EF 1L Input filter

Time constant, in seconds, of the RC input filter on the PV input. When this parameter is **OFF** the filter is bypassed.

Filter response

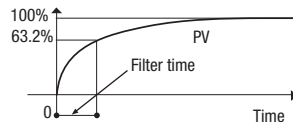

1n.5h Measure Bias

This value is added to the measured PV input value. Its effect is to shift the whole PV scale of its value (± 60 digits).

6.520 Sampling Time

Sampling time, in seconds, of the instrument. This parameter is normally used when controlling slow process, increasing the sampling time from 0.1... 10 s.

4.5.6 OUTPUT MENU

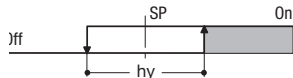
OP.HY Control output hysteresis

The parameter can be set between zero and 5% of the configured Span and set in Engineering units.

e.g. Range = -200...600°C
Span = 800°C

Max. Hyst. = 5% 800° = 40°C

t.c. Control output cycle time**t.c. C** Cool cycle time

This is the cycle time of the logic control output. The PID control output is provided by the pulse width modulation of the waveform.

OP.L Control Output low limit

It specifies the minimum value of the control output signal. It is also applied in manual mode.

OP.H Control output high limit**OP.C.H** Cool output high limit

This specifies the maximum value the control output. It is also applied in manual mode.

OP.r Heat output maximum rate**OP.r C** Cool output maximum rate

This value, specified in %/seconds, with a range from 0.01 to 99.99%/s provides the maximum rate of change of the output. When set to **OFF** this function is disabled.

SE.OP Soft start of the control output

This specifies the value at which the control output is set during the soft start phase.

SE.TN Soft start time

This value specifies the time the soft start phase lasts. The start up phase starts at power up of the controller.

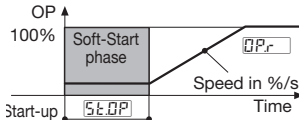
**TR.TN** Travel time

Provides the time required for the motor positioner to go from the 0% position to 100%

TR.HY Minimum step

This specifies the minimum allowed time activation of the output to a motor positioner that produces a sensible effect. It is related to the deadband of the positioner.

db.nd Heat/Cool deadband

This parameter specifies the width of the deadband between the Cool and the Heat outputs.

Heat / Cool Algorithm

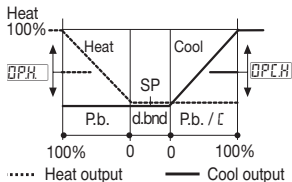

4.5.7 SERIAL COMMUNICATION MENU (OPTION)

Add.S

RS485 address communication
- 1...247

Add.P

SLAVE Profibus DP address
- 3...124

All instruments connected to the same supervisor must have different addresses. If set $\square F F$ the serial comm.s is not active.

bdr.S

SLAVE Baud rate

This provides the baud rate in the range 1200... 19200 bit/s.

PAR.Y

Parity

May be set even ($E u E n$) or odd ($o d d$). If $n o n E$ is set, parity will be excluded.

Prot

Protocol selection

$m b u s$ Modbus
 $j b u s$ Jbus
 $s s i$ Modbus SSI

Two serial communication options are available:

A - Modbus/Jbus SLAVE

The parameters value can be read and when possible modified.

B - PROFIBUS DP SLAVE

(**Process Field bus** protocol)
Industrial standard for peripheral devices connection to a machine in a plant.

The protocol installed in this controller offers the following advantages against the standard normally supplied by other suppliers:

- Communications baudrate
Up to 12 Mb/s with electric isolation.

- The list of data transfer (profile file) **is user configurable**. It can be set by means the configuration software [1]

Notes:

- [1]  **Please, read the user manual:**
“Serial communications and configuration software”.

4.5.8 TIME MENU

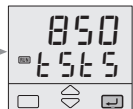

850
t5t5

Timer functions
rP5/run/End/
hold
(reset/run/quit/hold)



234
t.HH

Time set
(in hour)
0...9999



25
t.MM

Time set
(in minutes)
0...9999



60
t.b5

Band at timer
start
0...100



60
t.br

Band during
timer counting
0...100



t.b5

Time band Start
0... 100



t.br

Time band Run
0... 100 (only for
t.mod = 2, 3)

These two commands set the band at start time count and the band for the timer running.

4.6 PARAMETERIZATION - ACCESS MENU - PASSWORD - CALIBRATION

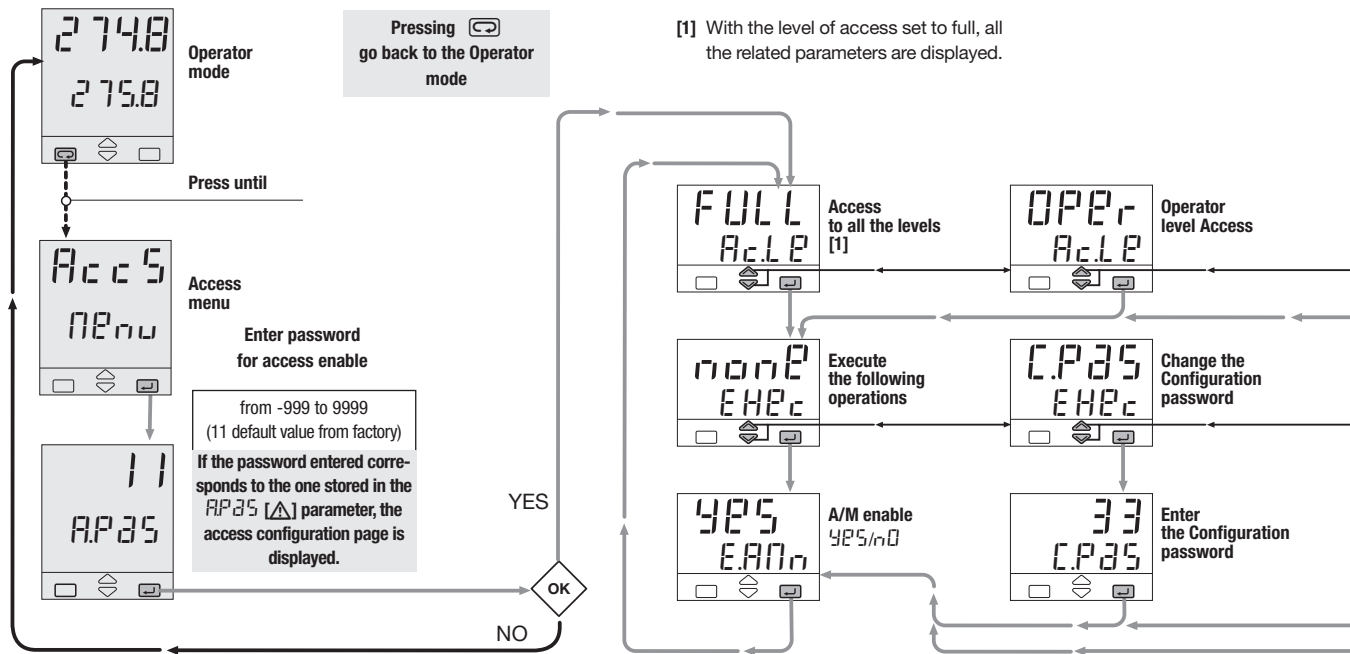

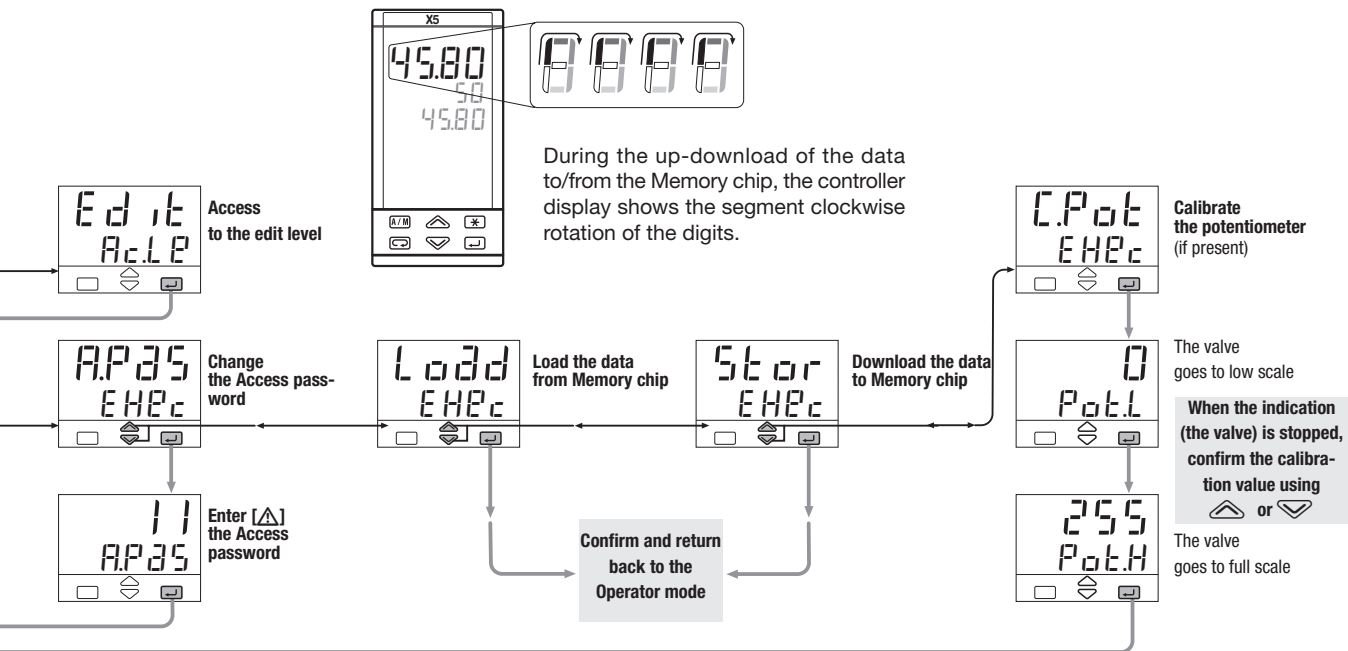



With the access level Edit, the user defines which groups and parameters are accessible to the operator

After selecting and confirming the access level Edit, enter in the parameters menu.

The code of the access level is displayed on the front panel.

Press the   keys to select the proper level.

Group of parameters	Code	Access level
	rEdD	Visible
	HiDE	Not visible (hidden)

Group of parameters	Code	Access level
	AlEr	Visible and changeable
	FaSt	Included in "Fast view"
	rEdD	Visible only
	HiDE	Not visible (hidden) and not changeable

The parameters in the access level Fast are recalled on the front panel through the procedure of fast parameter access illustrated in par. 5.2 page 57. The maximum number of fast parameters is 10.

At the end of the parameter list of the selected group, the controller exits from the Edit access level. **Therefore, the Edit level must be selected for each group of parameters**

The access level of groups and parameters is activated through:

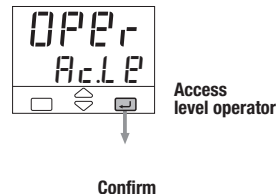

5

DISPLAYS

5.1 STANDARD DISPLAY

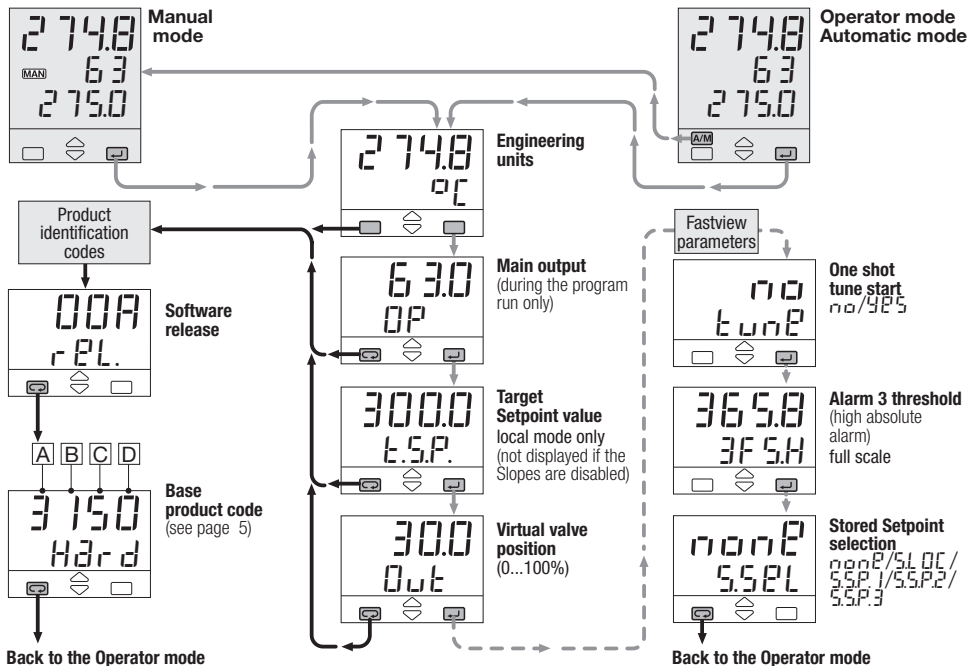

5.2 FAST VIEW

(fast access to the parameters)

With this procedure, up to 10 parameters, selected through the fast view (see par 4.6 page 56) are displayed and can be modified by the operator without requiring the standard parameter setting procedure. Press \uparrow \downarrow in order to modify the parameters. The value is entered by pressing \rightarrow key.

On left side, please find a sample list of parameters on Fast view menu.

6 COMMANDS

COMMANDS TO THE CONTROLLER AND OPERATING PHASES

The commands can be entered in 3 ways:



6.1 KEYPAD

see page 55

- Setpoint modification
- Manual mode
- Local/remote selection
- Stored Setpoint display
- Tune Run / Stop
- Program start/stop (see page 66)

6.2 DIGITAL INPUTS

see page 58

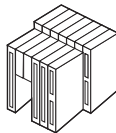

6.3 SERIAL COMMUNICATIONS

see the manual on this topic



6.1 KEYPAD COMMANDS

6.1.1 SETPOINT MODIFICATION

The **Setpoint** is directly modified with the   keys.

Once entered, the new value is checked and becomes operating after 2 seconds. The end of this phase is flagged by flashing momentarily the display with SP.

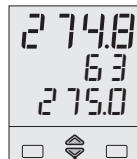

Operator mode

Example of Setpoint modification from 275.0 to 350.0

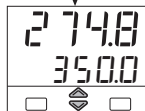

Modified Setpoint value



after 2 seconds



Flash momentarily the SP value to confirm that it has become operating. back to the operator mode

6.1.2 AUTO/MANUAL MODE

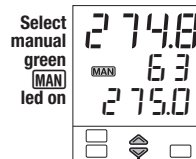

Select manual green led on

Modification of control output value



The new value is immediately working without any confirm.

Modify the output value

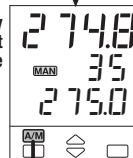

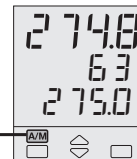

Back to the operator mode

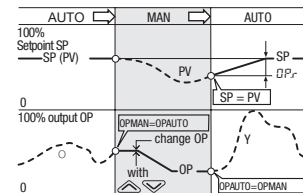

Operator mode (automatic)

The bumpless action is present switching between AUTO, MAN and vice versa.



 In case of power failure, the AUTO/MAN status and the output value remain stored in the controller memory.

6.1.3 LOCAL/ REMOTE SELECTION

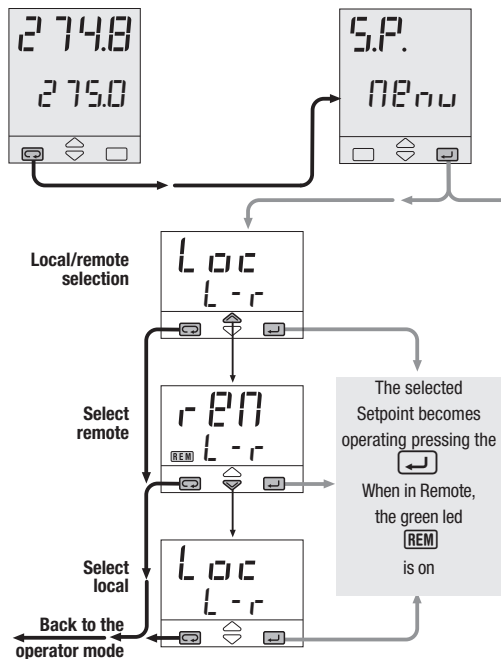

6.1.4 STORED SETPOINTS SELECTION (see also pages 42, 43)

The Setpoint is directly modified with the keys. Once entered, the new value is checked and becomes operational after 2 seconds. The end of this phase is flagged by flashing momentarily the display with SP.

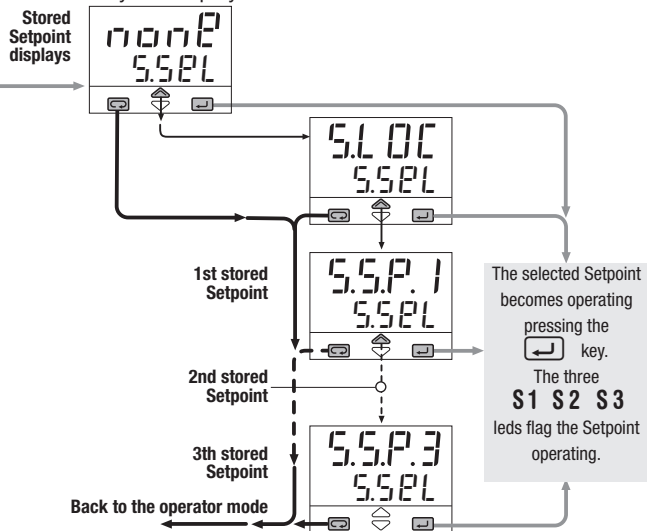

6.1.5 TUNE RUN / STOP

This controller is provided with 2 different Tuning algorithm:

- **Fuzzy tune (one shot tune)** for calculating the optimal PID term parameters.
- **Adaptive Tune** (continuous tune) for a continuous calculation of the PID term parameters.

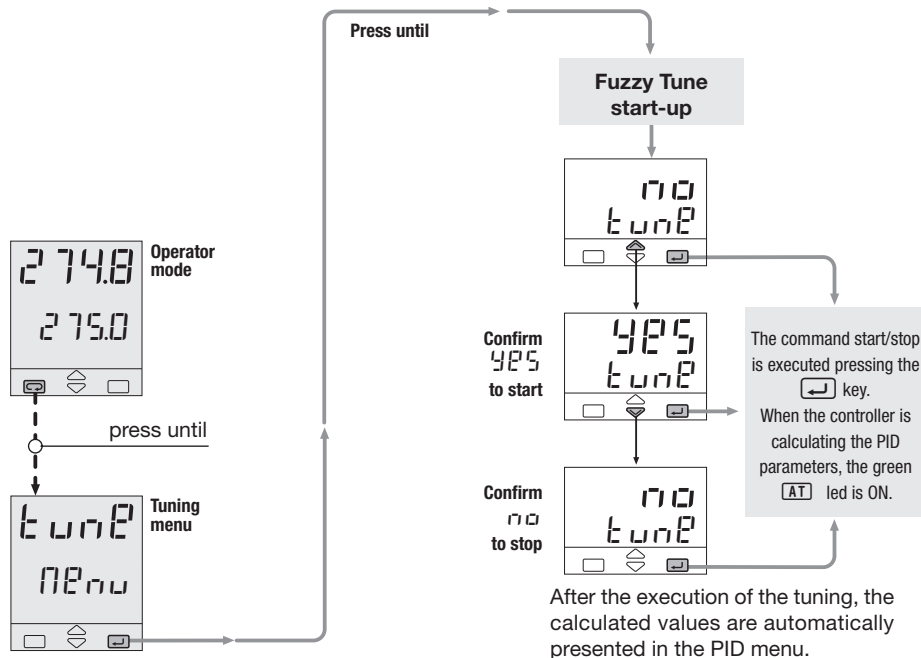



6.2 DIGITAL INPUTS COMMANDS

A function is assigned through the configuration procedure to each IL1, IL3 and IL3 digital input. (see the parameters setting at tab. 10 at page 30).

The configured function is activated when the digital input (free voltage contact or open collector output) is in the On state (closed). It is deactivated by setting the input to the Off state (open).

The activation of the function through the digital input has the highest priority than through the keypad or through the serial communication.

6.2.1 DIGITAL INPUTS COMMANDS FOR LOCAL-REMOTE SETPOINT

Function	Parameter value	Performed operation		Notes
		 Off	 On	
None	OFF	—	—	Not used
Set manual mode	MAN	Automatic	Manual	
Keyboard lock	KEYL	Unlock	Locked	With the keypad locked the commands from digital inputs and serial communications are still operating
PV measure hold	HPV	Normal operation	PV is hold	The value of PV is “frozen” at the time the digital input goes to the close state
Setpoint slopes inhibition	SLI	Rate limiting is active	Normal operation	When the input is in the on state, the Setpoint is changed in steps
Output forcing mode	FOR	Normal output	Forced output	With ON command the output is equal to the forced value (see page 28)
1st stored Setpoint	SP. 1	Local	1st SP	The permanent closure forces the chosen stored value. Setpoint modification is not possible.
2nd stored Setpoint	SP. 2	Local	2nd SP	The impulsive closure, selects the stored value. Setpoint modification is allowed. If more than one digital input is selecting a Setpoint, the last to be activated is the operating one (see page 43)
3th stored Setpoint	SP. 3	Local	3th SP	
Set Remote mode	L-r	Local	Remote	
Reactivation of blocking	BLCT	—	Reactivation of blocking	The blocking function is activated on closing the command from digital inputs
Start-Hold timer	StHt	—	—	Start-Hold timer
Reset Out 3	trPS	—	—	Reset Output 3 connected to the timer
End timer	End	—	—	Abort timer

8 TECHNICAL SPECIFICATIONS

Features at 25°C env. temp.	Description			
Total configurability (see chapter 4.3 page 25)	From keypad or serial communication the user selects: <ul style="list-style-type: none"> - the type of Setpoint - the type of control algorithm - the type of output <ul style="list-style-type: none"> - the type and functionality of the alarms - control parameter values - access levels 			
PV Input (see pages 13, 14 and page 26)	Common characteristics	A/D converter with resolution of 160,000 points Update measurement time: 50 ms Sampling time: 0.1... 10.0 s Configurable Input shift: - 60... + 60 digit Input filter with enable/disable: 0.1... 99.9 seconds		
	Accuracy	0.25% ±1 digits for temperature sensors 0.1% ±1 digits (for mV and mA)	Between 100...240Vac the error is minimal	
	Resistance thermometer (for ΔT: R1+R2 must be <320Ω)	Pt100Ω at 0°C (IEC 751) °C/°F selectable	2 or 3 wires connection Burnout (with any combination)	Max. wire Res: 20Ω max. (3 wires) Input drift: 0.1°C/10° T _{env} <0.1°C/10Ω Wire Res.
	Thermocouple	L, J, T, K, R, B, N, E, W3, W5 (IEC 584) R _j >10MΩ °C/°F selectable	Internal cold junction compensation con NTC Error 1°C/20°C ±0.5°C Burnout	Line: 150Ω max. Input drift: <2μV/°C. T _{env} . <5μV/10Ω Wire Res.
	DC input (current)	4... 20mA, 0... 20mA R _j =30Ω	Burnout. Engineering units conf. decimal point position with or without √ Init. Scale -999... 9999 Full Scale -999... 9999 (min. range of 100 digits)	
	DC input (voltage)	0... 50mV, 0... 300mV R _j >10MΩ 1... 5, 0... 5, 0... 10V R _j >10kΩ		
Frequency (option) 0... 2,000/0... 20,000Hz	Low level ≤2V High level 4... 24V			

Features at 25°C env. temp.	Description									
Auxiliary inputs	Remote Setpoint Not isolated accuracy 0.1%	Current: 0/4...20mA: Rj = 30Ω				Bias in engineering units and ± range Ratio: -9.99... +99.99 Local + Remote Setpoint				
		Voltage: 1... 5, 0... -5, 0... 10V: Rj = 300kΩ								
	Potentiometer	100Ω... 10kΩ				Feedback valve position				
Digital inputs 3 logic	The closure of the external contact produces any of the following actions:	Auto/Man mode change, Local/Remote Setpoint mode change, 3 Stored Setpoint activation, keyboard lock, measure hold, slope inhibit and output forcing Program Hold/Run (if option installed), Program Selection and Skip to Next Segment								
Operating mode and Outputs	1 single or double action PID loop or On/Off with 1, 2,3 or 4 alarms	Single action	Control output		Alarm	Alarm	Alarm	Alarm	Retransmission	
			Main (Heat)	Secondary (Cool)	AL1	AL2	AL3	AL4	PV / SP	
			OP1 Relay/Triac			OP2 Relay/Triac	OP3 Relay	OP4 Relay	OP5 Analog/Digital	OP6 Analog/Digital
		Double action Heat / Cool	OP5 Analog/Digital		OP1 Relay/Triac	OP2 Relay/Triac	OP3 Relay	OP4 Relay	OP5 Analog/Digital	OP6 Analog/Digital
			OP1 Relay/Triac	OP5 Analog/Digital		OP2 Relay/Triac	OP3 Relay	OP4 Relay		OP6 Analog/Digital
			OP5 Analog/Digital	OP2 Relay/Triac	OP1 Relay/Triac		OP3 Relay	OP4 Relay		OP6 Analog/Digital
			OP5 Analog/Digital	OP6 Analog/Digital	OP1 Relay/Triac	OP2 Relay/Triac	OP3 Relay	OP4 Relay		
		Valve drive	OP1 Relay/Triac	OP2 Relay/Triac			OP3 Relay	OP4 Relay	OP5 Analog/Digital	OP6 Analog/Digital

Features at 25°C env. temp.	Description			
Control mode	Algorithm	PID with overshoot control or On-off - PID with valve drive algorithm, for controlling motorised positioners		
	Proportional band (P)	0.5...999.9%		
	Integral time (I)	1...9999 s		
	Derivative time (D)	0.1...999.9 s	DFF = 0	
	Error dead band	0.1...10.0 digit		
	Overshoot control	0.01...1.00	Single action PID algorithm	
	Manual reset	0...100%		
	Cycle time (Time proportional only)	0.2...100.0 s		
	Min./Max output limits	0...100% separately adjustable		
	Control output rate limit	0.01...99.99%/s		DFF = 0
	Soft-start output value	1...100% - Time 1...9999 s		
	Output safety value	-100...100%		
	Control output forcing value	-100...100%		
	Control output hysteresis	0...5% Span in engineering units	On-Off algorithm	
	Dead band	0.0...5.0%	Double action PID algorithm (Heat / Cool)	
	Cool proportional band (P)	0.5...999.9%		
	Cool integral time (I)	1...9999 s		DFF = 0
	Cool derivative time (D)	0.1...999.9 s		
	Cool cycle time (Time proportional only)	0.2...100.0 s		DFF = 0
	Control output high limit	0...100%		
	Cool output max. rate	0.01...99.99%/s		
Motor travel time	15...600 s	Valve drive PID algorithm Raise/Stop/Lower		
Motor minimum step	to 0.1...5.0%			
Feedback potentiometer	100Ω ...10kΩ			

Features at 25°C env. temp.	Description				
OP1 - OP2 outputs	SPST Relay N.O., 2A/250Vac (4A/120Vac) for resistive load Triac, 1A/250Vac for resistive load				
OP3 output	SPDT relay N.O., 2A/250Vac (4A/120Vac) for resistive load				
OP4 output	RSPST relay N.O. 2A/250Vac (4A/120Vac) for resistive load				
Analog/digital OP5 and OP6 (option) outputs	Control or PV/SP retransmission	Galvanic isolation: 500 Vac/1 min Short circuit protected Resolution 12 bit Accuracy: 0.1 %	Analog: 0/1... 5V, 0...10V, 500Ω/20mA max., 0/4... 20mA, 750Ω/15V max.	Digital: 0/24Vdc ±10%; 30mA max. for solid state relay	
AL1 - AL2 - AL3 - AL4 alarms	Hysteresis 0...5% Span in engineering units				
	Action	Active high	Action type	Deviation threshold ±range	
		Active low		Band threshold 0... range	
	Special functions	Sensor break, heater break alarm			
		Acknowledge (latching), activation inhibit (blocking)			
Connected to Timer or program (if options installed) (only OP3-OP4)					
Setpoint	Local + 3 memorized				
	Remote only				
	Local and Remote				
	Local with trim				
	Remote with trim				

Features at 25°C env. temp.	Description		
Tuning	Fuzzy-Tuning type . The controller selects automatically the best method according to the process conditions	Step response Natural frequency	
	Adaptive Tune self-learning, not intrusive, analysis of the process response to perturbations and continuously calculation of the PID parameters		
Auto/Man station	Standard with bumpless function, by keypad, digital input or serial communications		
Serial comm. (option)	RS485 isolated, SLAVE Modbus/Jbus protocol, 1200, 2400, 4800, 9600, 19.200 bit/s, 3 wires RS485 isolated, MASTER Modbus/Jbus protocol, 1200, 2400, 4800, 9600, 19.200 bit/s, 3 wires RS485 asynchronous/isolated, PROFIBUS DP protocol, from 9600 bit/s at 12MB/s selectable, max. lenght 100m (at 12 Mb/s)		
Auxiliary Supply	+24Vdc \pm 20% 30mA max. - for external transmitter supply		
Operational safety	Measure input	Detection of out of range, short circuit or sensor break with automatic activation of the safety strategies and alerts on display	
	Control output	Safety and forcing value -100...100% separately adjustable	
	Parameters	Parameter and configuration data are stored in a non volatile memory for an unlimited time	
	Access protection	Password to access the configuration and parameters data - Fast view	
General characteristics	Power supply (PTC protected)	100... 240Vac (-15% +10%) 50/60Hz or 24Vac (-15% +25%) 50/60Hz and 24Vdc (-15% +25%)	Power consumption 5W max.
	Safety	Compliance to EN61010-1 (IEC 1010-1), installation class 2 (2500V) pollution class 2, instrument class II	
	Electromagnetic compatibility	Compliance to the CE standards (see page 2)	
	UL and cUL Approval	File E323812	
	Protection EN60529 (IEC 529)	IP65 front panel	
Dimensions	$\frac{1}{8}$ DIN - 48 x 96, depth 110 mm, weight 380 g max.		

FACTORY DEFAULT PARAMETERS

Parameter	Parameter Name	Default value	User settings	Notes
<i>5SEL</i>	Setpoint selection	NONE		
<i>SP.1</i>	1st stored Setpoint	0		
<i>SP.2</i>	2nd stored Setpoint	0		
<i>SP.L</i>	Setpoint low limit	PV.LO		
<i>SP.H</i>	Setpoint high limit	PV.HI		
<i>5 l.u</i>	Setpoint ramp up	OFF		
<i>5 l.d</i>	Setpoint ramp down	OFF		
<i>r t r o</i>	Ratio remote Setpoint	1.00		
<i>b i a s</i>	Remote Setpoint Bias	0		
<i>1</i>	AL1 alarm threshold	0		
<i>2</i>	AL2 alarm threshold	0		
<i>3</i>	AL3 alarm threshold	0		
<i>4</i>	AL4 alarm threshold	0		
<i>H3. l.u</i>	AL1 alarm hysteresis Up	1		
<i>H3. l.d</i>	AL1 alarm hysteresis Down	1		

Parameter	Parameter Name	Default value	User settings	Notes
<i>tF 11</i>	AL1 delay	1		
<i>H4.2u</i>	AL2 alarm hysteresis Up	1		
<i>H4.2d</i>	AL2 alarm hysteresis Down	1		
<i>tF 12</i>	AL2 delay	1		
<i>H4.3u</i>	AL3 alarm hysteresis Up	1		
<i>H4.3d</i>	AL3 alarm hysteresis Down	1		
<i>tF 13</i>	AL3 delay	1		
<i>H4.4u</i>	AL4 alarm hysteresis Up	1		
<i>H4.4d</i>	AL4 alarm hysteresis Down	1		
<i>tF 14</i>	AL4 delay	1		
<i>t.Oper</i>	Timer Operating Mode	0		
<i>t.act</i>	Timer Action	4		
<i>t.dOP</i>	Timer OP Function	1		
<i>t.h5u</i>	Hold time	0		
<i>S.P.5.u</i>	Start Up time	0		
<i>OP.h5</i>	Output limit during Startup	0		
<i>P_id</i>	PID Enable/disable	1		
<i>P.b.</i>	Proportional band	3.0		

Factory default parameters

Parameter	Parameter Name	Default value	User settings	Notes
<i>t.i.</i>	Integral time	60		
<i>t.d.</i>	Derivative time	12.0		
<i>dErr</i>	Error Dead Band	OFF		
<i>OC.</i>	Overshoot Control	0.8		
<i>OC.r.b.</i>	Overshoot Control relative band	1.0		
<i>PrPS</i>	Manual Reset	50		
<i>Pb. C</i>	Cool proportional band	3.0		
<i>t.i. C</i>	Cool integral time	60		
<i>t.d. C</i>	Cool derivative time	12.0		
<i>t.unP</i>	Start/Stop One shot tuning (0=Stop 1=Run)	NO		
<i>AdPt</i>	Start/Stop Adaptive tuning (0=Stop 1=Run)	NO		
<i>t.F. I</i>	Input filter	2.0		
<i>InSh</i>	Input shift	OFF		
<i>t.S_{amp}</i>	Sampling time	0.1		
<i>OP.H_y</i>	Output Hysteresis	1		
<i>t.c.</i>	Cycle time	5.0		
<i>OP.L</i>	Control output low limit	0.0		
<i>OP.H</i>	Control output high limit	100.0		

Parameter	Parameter Name	Default value	User settings	Notes
<i>OP.r</i>	Control output maximum speed	OFF		
<i>St.OP</i>	Soft start output high value	OFF		
<i>St.tn</i>	Soft start time	10		
<i>n.t</i>	Output minimum step Servomotor	60		
<i>n.h9</i>	Output minimum step Servomotor	0.5		
<i>dbnd</i>	Heat/Cool Dead band	0.5		
<i>t.c.t</i>	Cool cycle time	5.0		
<i>OP.C.H</i>	Cool output maximum value	100.0		
<i>OP.r.C</i>	Cool output maximum speed	OFF		
<i>Addr.S</i>	Communication SLAVE address	247		
<i>dr.S</i>	SLAVE Baud rate	9600		
<i>Pro.S</i>	SLAVE Communication protocol	MBUS		
<i>Par.Y</i>	Parity	NONE		
<i>MaSt</i>	Enable MASTER	NO		
<i>dr.M</i>	MASTER Baud rate	9600		
<i>Pro.M</i>	MASTER Communication protocol	MBUS		
<i>Addr.P</i>	PROFIBUS DP address	3		
<i>C.PAS</i>	Configuration password	33		

Factory default parameters











Parameter	Parameter Name	Default value	User settings	Notes
<i>APPS</i>	Access password	11		
<i>In</i>	Input type selection	0 - 10		
<i>Unit</i>	Engineering units	NONE		
<i>SC.dd</i>	Number of decimals (0... 3)	0		
<i>SC.la</i>	Low range	0		
<i>SC.Hi</i>	High range	9999		
<i>Sqr</i>	Square root (0 = OFF, 1 = ON)	NO		
<i>Chdr</i>	Linear input characterization	NO		
<i>SPtY</i>	Setpoint type	LOC		
<i>SPtr</i>	Stored Setpoint tracking	NO		
<i>SPF</i>	Time units and Setpoint slope	P.SECOND		
<i>.In</i>	Remote Setpoint input	4 - 20		













■ WARRANTY











We guarantee this product to be free from defects in material and workmanship for 3 years from the date of shipment.

The warranty above shall not apply for any failure caused by the use of the product not in accordance with the instructions in this manual.

ICONS TABLE

Main universal input	
	Thermocouple
	RTD (Pt100)
	Delta Temp (2x RTD)
	mA and mV
	Custom
	Frequency
Auxiliary input	
	Current transformer
	mA Remote setpoint
	Volt Remote setpoint
	Feedback potentiometer

Digital input	
	Isolated contact
	NPN open collector
	TTL open collector
Setpoint	
	Local
	Stand-by
	Keypad lock
	Outputs lock
	Start-up function
	Timer function
	Memorized
	Remote
	Setpoint programmer

Digital input connected functions	
	Auto/Manual
	Run, Hold, Reset and program selection
	PV hold
	Setpoint slopes inhibition
Output	
	SPST Relay
	Triac
	SPDT Relay
	mA
	mA mV
	Logic

Super Systems Inc.

USA Office

Corporate Headquarters:

7205 Edington Drive

Shipping Address:

7245 Edington Drive

Cincinnati, OH 45249

Phone: (513) 772-0060

<http://www.supersystems.com>

Super Systems Europe

Unit E, Tyburn Trading Estate,

Ashold Farm Road, Birmingham

B24 9QG

UNITED KINGDOM

Phone: +44 (0) 121 306 5180

<http://www.supersystemseurope.com>

Super Systems México

Sistemas Superiores Integrales S de RL de CV

Acceso IV No. 31 Int. H Parque Industrial

Benito Juarez

C.P. 76120 Queretaro, Qro.

Phone: +52 442 210 2459

<http://www.supersystems.com.mx>

Super Systems China

No. 369 XianXia Road

Room 703

Shanghai, CHINA

200336

Phone: +86 21 5206 5701/2

<http://www.supersystems.cn>

Super Systems India Pvt. Ltd.

A-26 Mezzanine Floor, FIEE Complex,

Okhla Indl. Area, Phase - 2

New Delhi, India 110 020

Phone: +91 11 41050097

<http://www.supersystemsindia.com>